

International Association of Chiefs of Police

Lidar Performance Standards

Volume 1 dated June 1, 2004

SPEED-MEASURING DEVICE

PERFORMANCE SPECIFICATIONS:

LIDAR MODULE

FOREWORD

This document contains the lidar speed-measuring model minimum performance specifications for lidar devices and lidar systems developed under an Interagency Agreement with the National Institute of Standards and Technology, Office of Law Enforcement Standards.

This document supersedes the Model Performance Specifications for Lidar Speed-Measurement Devices (DOT HS 809 239), July 2001 and all prior versions.

By defining minimum performance requirements and verification procedures, this technical document establishes a baseline for acceptable traffic lidar speed-measuring device and lidar system performance. Citizens, courts and law enforcement officers should be assured that those lidar speed-measuring models, determined by test to comply with these specifications, will provide the high quality of service they require.

Lidar equipment buyers should use these performance specifications as a model to develop purchasing criteria. It is recommended that these specifications be incorporated into procurement documents requiring that lidar devices and lidar systems offered for purchase meet, as a minimum, these specifications.

Manufacturers are encouraged to produce lidar speed-measuring devices and lidar systems that meet or exceed these performance specifications.

Because this NHTSA document is designed as a development and procurement aid, it is necessarily highly technical.

These performance specifications are subjected to continuing review. Technical comments and recommended revisions are welcome. Please send suggestions to:

Enforcement and Justice Services Division
National Highway Traffic Safety Administration
400 Seventh Street, S.W., NTS-13
Washington, D.C. 20590

Before citing these performance specifications, or any part of them, users should verify that the most recent edition of this document is being used.

NHTSA believes that these performance specifications will assist law enforcement administrators in determining the accuracy and reliability of lidar devices and lidar systems they plan to purchase. NHTSA also believes that these performance specifications and testing protocols will increase the confidence of law enforcement officers, the public and the courts in the accuracy and reliability of this equipment.

ACKNOWLEDGMENTS

The National Highway Traffic Safety Administration wishes to express its appreciation to the following individuals that have contributed to the publication of this document.

A. George Lieberman, Ph.D.
Program Manager, Office of Law Enforcement Standards
National Institute of Standards and Technology

Richard R. Larson
Speed Measurement Program Manager
International Association of Chiefs of Police

Members of the Enforcement Technologies Advisory Technical Subcommittee
(E.T.A.T.S.), Highway Safety Committee, International Association of Chiefs of
Police.

Appreciation is also extended to the manufacturers of lidar speed-measuring devices for their cooperation in the preparation of this document.

TABLE OF CONTENTS

	<u>Page</u>
Foreword	i
Acknowledgments	iii
Section 1 – General Information	
1.1 Scope	1-1
1.2 Purpose	1-1
1.3 Application	1-1
1.4 Definitions	1-1
1.5 Units of Measure	1-4
Section 2 – Requirements	
2.1 Manufacturer Provided Equipment	2-1
2.2 Manufacturer Provided Information	2-2
2.3 Manufacturer Labeling	2-3
2.4 Range Accuracy	2-3
2.5 Long Range	2-3
2.6 Beam Characteristics	2-4
2.7 Environmental Extremes	2-4
2.8 Low Supply Voltage Indicator	2-4
2.9 Supply Voltage Tolerance	2-5
2.10 Speed Display	2-5
2.11 Speed Accuracy: Laboratory Simulation	2-6
2.12 Auxiliary-Equipment Interface	2-6
2.13 Conducted Electromagnetic Interference	2-7
2.14 Radiated Electromagnetic Interference	2-8
2.15 Speed Accuracy: Field Operation	2-8
2.16 Vehicle Determination (Lidar Systems Only): Field Operation.....	2.8
Section 3 – Test Conditions	
3.1 Standard Conditions	3-1
Section 4 – Test Equipment	
4.1 Test Equipment	4-1
4.2 Tripod	4-1
4.3 Test Range for Target Distance Feature	4-1
4.4 Long-Range Target	4-2
4.5 Beamwidth Measurement Apparatus	4-2
4.6 Environmental Chamber	4-2
4.7 Target Speed Simulator Based on Digital Delay Generator	4-2
4.8 Computer	4-3
4.9 Counter-Timer Interface Card	4-3
4.10 Digital Delay Generator	4-3
4.11 Pulse Generator	4-3
4.12 Sawtooth Wave Generator	4-3
4.13 Pulse-Sawtooth Coupling Circuit	4-3

4.14	FM Signal Generator	4-4
4.15	AM Signal Generator	4-4
4.16	Line Impedance Stabilization Network (LISN)	4-4
4.17	RF Power Meter	4-4
4.18	Slide Whistle	4-4
4.19	Oscilloscope	4-4
Section 5 – Test Procedures		
5.1	(Reserved).....	5-1
5.2	(Reserved).....	5-1
5.3	Labeling and Operation Tests.....	5-1
5.4	Range Accuracy Test	5-1
5.5	Long-Range Test.....	5-1
5.6	Beam Characteristics Test.....	5-2
5.7	Environmental Tests.....	5-2
5.8	Low Supply Voltage Indicator Test	5-3
5.9	Supply Voltage Tolerance Tests.....	5-4
5.10	Speed Display Tests.....	5-4
5.11	Speed Accuracy: Laboratory Simulation Tests	5-6
5.12	Auxiliary-Equipment Interface Tests	5-8
5.13	Conducted Electromagnetic Interference Tests	5-8
5.14	Radiated Electromagnetic Interference Tests.....	5-10
5.15	Speed Accuracy: Field Operation Tests	5-11
5.16	Vehicle Determination (Lidar Systems Only): Field Operation....	5-12
Appendix		
Table 1 -	Minimum Performance Requirements for Lidar Speed Measuring Devices and Systems	A-2
Figure 1 -	Block diagram of target simulator.....	A-3
Figure 2 -	Schematic for the test range for target distance feature.....	A-4
Figure 3 -	Block diagram of the pulse-sawtooth coupling circuit.....	A-5
Figure 4 -	Oscillogram of a rectangular pulse, coupled through the circuit of figure 3 into the 10 Ω dummy load	A-6
Figure 5 -	Block diagram of the line impedance stabilization network (LISN)	A-7
Figure 6 -	Schematic of the long-range target apparatus	A-8
Figure 7 -	Schematic of the beam characterization apparatus	A-9
Figure 8 -	Block diagram of the low voltage test circuit.....	A-10
Figure 9 -	Block diagram of the radio-frequency test circuit.....	A-11

Section 1 - General Information

1.1 Scope

This module is limited in scope to laser speed-measuring devices and systems used by law enforcement agencies to enforce vehicle speed regulations. It applies to devices that comply with FDA Class 1 eye safety regulations (§ 2.2.3).

1.2 Purpose

The purpose of this module is to specify minimum performance specifications and test procedures for lidar devices used by law enforcement agencies to enforce vehicle speed regulations.

1.3 Application

This document applies to laser speed-measuring devices and systems that transmit coherent infra-red light pulses, measure the time of flight for the pulses reflected from moving vehicles, then calculate and display or output the speed of the target vehicle, and may automatically record images of those vehicles which exceed a preset speed.

1.4 Definitions

1.4.1 Accuracy - the degree to which the lidar device measures and displays the speed of a vehicle.

1.4.2 Acquired Target - a vehicle that enters the beam of a lidar device, allowing for a measurement of its speed.

1.4.3 Ambient Interference - the conducted and/or radiated electromagnetic interference and/or mechanical motion interference at a specific test location and time that might be detrimental to proper lidar device performance.

1.4.4 Attended Operation - an operator is an integral part of the evidence acquisition process.

1.4.5 Automatic Lock - a control function of a lidar device that, when activated, causes the device to automatically retain the displayed speed of a target vehicle whenever the target speed exceeds some preset value, and to preserve that displayed speed until manually reset by the operator.

1.4.6 Certified Radar Unit - a radar unit selected from the IACP's current Consumer Products List (CPL) that has been modified by its manufacturer to display speed in one-tenths units and certified by an IACP-approved testing laboratory to be accurate to within +0.2 km/h, -0.3 km/h (+0.1 mph, -0.2 mph) over a speed range of 32 km/h to 144 km/h (20 mph to 90 mph).

1.4.7 Closing Speed - the speed at which a target is moving toward the speed-measuring device, measured as the rate of change of the distance separating the device and the target.

1.4.8 Cosine Angle Effect - the discrepancy between the target vehicle's speed along its path and the closing speed measured by the device.

1.4.9 Display - a visual readout device.

1.4.10 Erroneous Reading - an incorrect target speed displayed by the lidar device that is not due to a target vehicle, or which is not within the required accuracy tolerance of a target vehicle's speed after accounting for the cosine angle effect.

1.4.11 Functional Beamwidth - the angular range over which a small, stationary retro reflective target can be detected against a background of sky or distant scenery.

1.4.12 Horizontal Beamwidth - the functional beamwidth measured in the horizontal plane, usually expressed in milliradians (mrad).

1.4.13 I/O Port - Input/Output interface for connecting external devices to the lidar unit.

1.4.14 Laser Speed-Measuring Device - a lidar unit.

1.4.15 LCD - Liquid Crystal Display; a type of electronic display.

1.4.16 LED - Light Emitting Diode; a type of electronic display.

1.4.17 Lidar - (from Light Detection And Ranging) the technology of measuring target range using reflected light. In today's engineering usage lidar includes many intricate devices, but this standard is concerned with class of lidar devices that determine target range and speed from the time-of-flight of laser pulses.

1.4.18 Lidar Device (Unit) - down-the-road speed-measuring equipment which, determines target range and speed based on the time-of-flight of laser light pulses reflected off a target. Lidar device is synonymous with "laser speed-measuring device" and "lidar unit" for the purpose of this standard.

1.4.19 Lidar System - A lidar device that incorporates additional equipment that is used to gather, process and/or recorded images to be used as part of speed enforcement efforts.

1.4.20 Nominal Value - the numerical value of a performance characteristic of a device as specified by the manufacturer or as used for identification. For instance, vehicle batteries often have a nominal voltage of 12 V, although in normal driving the terminal voltage can be above 14 V.

1.4.21 Operational Test - a test involving realistic conditions of operation. For instance, a lidar unit receiving its power from a stationary patrol vehicle and used to measure the speed of another vehicle traveling at a known speed.

1.4.22 Range - the distance from the reference plane of the lidar unit to the point where the transmitted beam strikes the target, for which valid distance measurements can be acquired.

1.4.23 Recorded Images - images recorded on photographs, microphotographs, electronic images, videotape, or any other medium.

1.4.24 Remote Control - a means by which many functions of the lidar unit can be controlled through a computer or a separate control panel.

1.4.25 Remote Trigger - a means by which the lidar unit can be triggered remotely. It is envisioned (though not required) that a remote control would involve a two-way computer data link, while a remote trigger can be as simple as a pair of wires leading from a switch to the lidar unit.

1.4.26 RS-232 - an Electronics Industries Association (EIA) standard for serial digital communications. Historically, this standard was put into wide use before the details were well-defined, and it was often a challenge to interconnect two devices claiming to meet RS-232 specifications. In the 1980s, following the adoption of standard RS-232 by EIA, implementation became more consistent.

1.4.27 Serial Port - a module within a computer or a computerized instrument which permits communication over a cable. The individual bits of a data byte are sent or received one after the other, or "serially."

1.4.28 Target Discrimination - the ability of a speed-measuring device to differentiate between target vehicles.

1.4.29 Target Speed - the speed of the target vehicle along its path, with respect to the ground.

1.4.30 Target Speed Simulator - a laboratory device capable of receiving light pulses from a lidar unit and then sending return pulses with changing delays. The changing delays simulate a target vehicle moving at a specified speed and direction, and at a particular range.

1.4.31 Target Vehicle - the vehicle at which the lidar unit is aimed using the unit's visual sighting device.

1.4.32 Unattended Operation - an operator is not an integral part of the evidence acquisition process.

1.4.33 UUT - unit under test.

1.4.34 Unit Under Test - a lidar device or lidar system whose performance is being tested, as distinguished from other equipment used to do the test.

1.4.35 Vertical Beamwidth - the functional beamwidth measured in the vertical plane, usually expressed in milliradians (mrad).

1.5 Units of Measure

This document is a specification for practical measuring devices of comparatively low precision. The goal has been to make rules that are practical, whether the UUT reads in kilometers per hour (km/h) and meters (m), or miles per hour (mph) and feet (ft). The speed accuracy requirement as stated below is +2 km/h, -3 km/h (+1 mph, -2 mph). Direct conversion from km/h to mph would give a tolerance band of +1.24 mph, -1.86 mph. Practical lidar devices read to integer precision only, so some decision must be made in order to give the tolerances in integers.

The same spirit of practicality is carried over into other measurements. For instance, to check a lidar device's distance measurement function, two somewhat arbitrary baselines are needed, as specified in §2.4.1. One baseline shall be in the range of 6 m (20 ft) to 30 m (100 ft), and the other shall be at least 90 m (300 ft). Again, the conversions are not exact.

In the simulator software, the settings for the primary system of units are those that are appropriate for the UUT. These determine the ranges and units of most inputs and outputs. Again, some liberty was taken in rounding the range limits. The presence of round off discrepancies should not motivate sloppy measurement. When the actual baseline is set up, it should be measured by surveying methods to an accuracy of 1 cm or better. Also, if the measured baseline is, for instance, 90 m (295.28 ft), a traditional-units lidar device should be moved forward 0.28 ft from the fiduciary mark, so that it is presented with a less ambiguous measurement task.

Section 2 - Requirements

2.1 Manufacturer Provided Equipment

The following equipment shall be provided by the lidar unit's manufacturer to the test laboratory, as applicable. Such equipment shall remain the property of the lidar unit's manufacturer and be returned upon completion of testing unless other agreements are made.

The manufacturer of a lidar device or lidar system who is requesting approval of a characteristic that is outside the specifications contained in this document is required to provide suggested revisions for review by the appropriate IACP Highway Safety Committee designee when submitting the UUT. The manufacturer shall supply any adapters or unique test equipment required to test the UUT.

2.1.1 Tripod Adapter. In parts of the acceptance testing, a tripod must be used to steady the lidar unit. If a lidar unit requires an adapter for mounting to a tripod, the manufacturer shall furnish the adaptor.

2.1.2 I/O Port Test Setup. If the lidar unit features an I/O port for output that is claimed to meet a standard such as RS-232, the manufacturer shall supply the cabling and simple software with which the test laboratories can connect the UUT to a PC-compatible computer or other intended device and test the operation of the I/O port. In this context, "simple software" means a short program in a high-level language such as BASIC or C, with source code supplied. The purpose of this software is to verify the operation of the port, and it may be different from proprietary software provided for police use.

2.1.3 Switching Output Indicator Box. If a switching output is claimed, the manufacturer shall supply the test laboratories with cabling and a simple indicator box which can be used to verify this output. The indicator box, which might contain such parts as a battery, a resistor, and an LED, shall be accompanied by a schematic and shall make the voltage at the switched pins accessible for measurement.

2.1.4 Remote Control Test Setup. If remote control by computer is claimed, the manufacturer shall supply the cabling and simple software with which the test laboratories can connect the UUT to a PC-compatible computer and test the data input functions. In this context, "simple software" means a short program in a high-level language such as BASIC or C, with source code supplied. This simple software may be different from proprietary software provided for police use. If the simple software does not exercise all remote-control functions and proprietary PC-compatible software is available for this purpose, that software shall also be supplied. Source code of the proprietary software is not required.

2.1.5 Remote Trigger Test Setup. If the unit to be tested has a remote trigger input in lieu of or in addition to a remote control port, the manufacturer shall provide a switch

box and cable to the test laboratories. The switch box shall have parts that are visible and electrically accessible for testing. If the switch box incorporates parts beyond a switch, a schematic shall be supplied.

2.1.6 Receive-Send Unit. This specification requires the lidar unit to be tested on a target simulator, which may return light pulses of a different shape and energy level from those of a real target. Each lidar device submitted for testing must interact properly with the simulator. The manufacturer may, at its option, supply the receive-send unit to be used with its lidar device; or it may supply an interface, perhaps employing fiber optics, to deal with the optical aspects of the receive-send interface.

2.2 Manufacturer Provided Information

Each lidar device submitted for testing in accordance with the provisions of these specifications shall be accompanied by the following minimum information:

2.2.1 Complete Operating Instructions. This includes test procedures, required maintenance, and any operating characteristics that are indicative or symptomatic of possible malfunction of the lidar unit.

2.2.2 Laser Wavelength. The operating wavelength of the lidar unit.

2.2.3 Laser Safety Classification. The lidar unit is regulated by the Center for Devices and Radiological Health (CDRH) of the Food and Drug Administration (21 CFR 1040.10 and 1040.11 or as amended).

2.2.4 Nominal Power Supply Voltage and Currents. Separate current values for different operating states, as appropriate.

2.2.5 Supply Voltage Limits. The lowest and highest supply voltages at which the lidar unit is designed to operate, the low voltage alert threshold value and display behavior.

2.2.6 Image Recording Equipment. The image recording equipment shall be submitted to support testing where applicable. The image recording equipment submitted for testing in accordance with the provisions of these specifications shall be accompanied by the following minimum information:

2.2.6.1 *Installation instructions.* Complete instructions for connecting the supplied equipment to the lidar device and verifying their operation, including test procedures, required maintenance, and operating conditions indicative or symptomatic of a possible malfunction of the lidar system.

2.2.6.2 *Operating instructions.* Complete instructions for operating the supplied equipment.

2.2.7 Speed Measurement Range. Expressed as the highest and lowest speeds that can be measured by the lidar unit for approaching or receding targets.

2.2.8 Temperature Limits. The highest and lowest temperatures at which the lidar system is designed to operate.

2.2.9 Temperature-Humidity Limit. The highest temperature and humidity combination at which the lidar system is designed to operate.

2.2.10 Reference Plane. The plane on the lidar unit from which distance measurements are taken. If not stated, the reference plane is assumed to be the front surface of the device.

2.2.11 Horizontal and Vertical Functional Beamwidths. Functional beamwidths shall be stated in milliradians.

2.2.12 Triggering. A description of when the lidar unit should be triggered during the operational speed accuracy test. The operational speed accuracy test depends on a baseline on the ground, for instance two marks approximately 400 m ($\frac{1}{4}$ mile) apart. The lidar should be triggered so that it measures the speed over nearly the same baseline each time the measurement is repeated. This may involve triggering the lidar unit as the test vehicle begins to traverse the baseline, or tracking the vehicle and releasing the trigger at a certain point. Due consideration must be made to coordinate the lidar speed reading with readings of the certified radar unit, the test vehicle's speedometer and the average speed (stopwatch-timed distance) of the test vehicle as set forth in § 5.15.2.

2.2.13 Pulse Repetition Rate. The Manufacturer shall provide the pulse repetition rate (PRR).

2.3 Manufacturer Labeling

The control panel of the lidar device shall be permanently marked with the functions and settings of all switches, controls, and displays. It shall not be possible to set the controls to a functional mode of operation that is not explained in the user manual. Every control shall be labeled, and the labeling shall, at a minimum, be consistent with one of the functions of the control (§5.3).

2.4 Range Accuracy

For a baseline distance between 6 m (20 ft) to 30 m (100 ft) and for a baseline distance at least 90 m (300 ft), the target range reading shall be correct to within ± 0.3 m (± 1 ft).

2.5 Long Range

The lidar unit shall be capable of measuring distances of at least 300 m (1000 ft).

2.6 Beam Characteristics

2.6.1 Beam Alignment. The transmitted beam and the sighting optics of the lidar unit shall be properly aligned, both horizontally and vertically, in accordance with §5.6.1.

2.6.2 Range. The lidar unit shall accurately display the range of each presented target as measured in accordance with § 5.6.2.

2.6.3 Target Discrimination. The functional beamwidth of the lidar unit shall not exceed 5 mrad as tested in accordance with §5.6.3.

2.7 Environmental Extremes

Any lidar system not enclosed in an environmentally-controlled cabinet shall be tested to determine the ability of the lidar system to operate in environmental extremes using the test methods described in §5.7. Lidar systems in an environmentally enclosed cabinet shall be certified by the manufacturer to comply with (§2.7.1.1) and (§2.7.2).

2.7.1 Operational Temperatures

2.7.1.1 Lidar Device Temperature Limits Let $T_{d_{Low}}$ be defined as $-30\text{ }^{\circ}\text{C}$ ($-22\text{ }^{\circ}\text{F}$) or the lowest temperature at which the manufacturer states that the lidar device will operate properly (§2.2.7), whichever is lower. Let $T_{d_{High}}$ be defined as $60\text{ }^{\circ}\text{C}$ ($140\text{ }^{\circ}\text{F}$) or the highest temperature at which the manufacturer states that the device will operate properly (§2.2.7), whichever is higher. Then, when tested in accordance with §5.7.1, following exposure to $T_{d_{Low}}$ or $T_{d_{High}}$, each lidar device shall continue to be able to generate speed reading that meet the speed accuracy requirements of §2.11.

2.7.1.2 Lidar System Temperature Limits Let $T_{s_{Low}}$ be defined as the lowest temperature at which the manufacturer states that the lidar system will operate properly (§2.2.7). Let $T_{s_{High}}$ be defined as the highest temperature at which the manufacturer states that the lidar system will operate properly (§2.2.7). Then, when tested in accordance with §5.7.1, following exposure to $T_{s_{Low}}$ or $T_{s_{High}}$, each lidar system shall continue to be able to generate speed reading that meet the speed accuracy requirements of §2.11. In addition when a lidar system is tested in accordance with §5.7.1, following exposure to $T_{d_{Low}}$ or $T_{d_{High}}$, the lidar system shall not generate any erroneous speed readings. During these tests, a blank target speed display is not an erroneous reading.

2.7.2 Operational Humidity. When tested in accordance with §5.7.2 following exposure to 90 % relative humidity at $37\text{ }^{\circ}\text{C}$ ($99\text{ }^{\circ}\text{F}$) for a minimum of 8 h, each lidar device or lidar system shall continue to meet the speed accuracy requirements of §2.11.

2.8 Low Supply Voltage Indicator

Each lidar device shall have a low voltage indicator that alerts the operator either visually or audibly when the supply voltage is reduced below threshold. For a device

intended to operate from a nominal 12 V automotive system, this indicator shall activate if the supply voltage is reduced to 10.8 V, or to the lowest voltage specified by the manufacturer (§2.2.5), whichever is lower. For devices utilizing a battery pack, this indicator shall activate if the supply voltage is reduced to the lowest operating voltage specified by the manufacturer (§2.2.5). When tested according to §5.8, the lidar unit shall not display any erroneous readings or below, the threshold voltage that activates the indicator. A blank display is not an erroneous reading.

2.9 Supply Voltage Tolerance

The requirements of this section shall be satisfied when the lidar device is tested in accordance with §5.9. For a device intended to operate from a nominal 12 V automotive system, the requirements shall be met if the voltage is raised 20 % above the standard supply voltage (§3.1.3), or to the manufacturer's specified limit if higher, and when lowered 20 % below the standard supply voltage or to the manufacturer's specified lower voltage limit, if lower. For devices utilizing a battery pack, the requirements shall be met if the voltage is raised to the manufacturer's specified upper limit and reduced to the manufacturer's specified lower limit (§2.2.5).

2.9.1 Pulse Repetition Rate. The pulse repetition rate shall not vary by more than 0.1 % from its value at the standard supply voltage.

2.9.2 Range and Speed. The UUT shall interact with the simulator at various range and speed settings and continue to meet the speed accuracy requirements of §2.11.

2.10 Speed Display

The speed display characteristics listed below shall be tested in accordance with §5.10 and shall meet the following requirements:

2.10.1 Display Readability. The display shall be clearly readable when tested in accordance with §5.10.1 and used as intended by the manufacturer.

2.10.2 Speed-Display Lock. The lidar unit may include a means to lock a vehicle's speed in the display. The speed-display lock function shall require manual actuation by the lidar operator and shall not be capable of automatic self-lock. The lidar unit shall not recall a previous speed reading when the speed- display-lock function is activated (§5.10.2).

2.10.3 Display-Clear Function. When the lidar unit is activated to begin a new measurement, the display shall be cleared of any previous reading (§5.10.3).

2.10.4 Internal-Circuit-Test Function. The lidar device shall have a self-test function that, when activated, determines if the internal signals will be processed and displayed to within ± 2 km/h (± 1 mph). The lidar device shall display the correct reading(s) when performing the internal circuit test function, or the lidar device shall display an error

message at the end of the test if the test function fails. It shall not be possible for the lidar device to lock in speeds displayed by this test. The internal circuit test switch shall not be labeled cal or calibrate.

2.10.5 Low and High Speed Display Limits

2.10.5.1 *Low Speed.* The lidar unit shall function as specified in test procedure §5.10.5 at a speed of 16 km/h (10 mph) or the lowest speed at which the manufacturer states that the device will operate properly, whichever is lower.

2.10.5.2 *High Speed.* The lidar unit shall function as specified in test procedure §5.10.5 at a speed of 320 km/h (200 mph) or the highest speed at which the manufacturer states that the device will operate properly, whichever is higher.

2.10.6 Audio Tones and Error Messages. If the lidar unit emits audio tones which vary under conditions of valid and invalid data, then the relationship of the sounds to the displayed reading shall be consistent (§5.10.6).

2.10.7 Speed Monitor Alert. The lidar device shall not have a speed monitoring alert capability (§5.10.7).

2.11 **Speed Accuracy: Laboratory Simulation**

For simulated speeds of 16 km/h to 320 km/h (10 mph to 200 mph), each lidar unit shall display the speed to within +2 km/h, -3 km/h (+1 mph, -2 mph). For speed accuracy requirements for field operation, see §2.15.

2.11.1 Smoothly Moving Target. When tested on the simulator in accordance with §5.11.1 at twenty or more combinations of speed and distance which are within its working range, the lidar unit shall give no erroneous speed readings. A blank display is not in itself an erroneous reading, but trials that give a blank display or an error message shall be repeated, and the unit shall ultimately give an accurate speed reading at every setting tried. There is no requirement on the range reading in this test.

2.11.2 Smoothly Moving Target with Sawtooth Perturbation. The simulator permits a periodic perturbation in distance to be added to the simulation of a smoothly moving target. When tested on the simulator in accordance with §5.11.2, using a perturbation with an approximate sawtooth shape having a period of about 200 ms and a peak-to-peak amplitude corresponding to a distance of about 1.5 m (5 ft), the lidar unit shall give no erroneous speed readings. A blank display is not an erroneous reading.

2.12 **Auxiliary Equipment and Interface**

Auxiliary equipment needed for testing shall be present and working.

2.12.1 Output Port. An output port is not required. If a model has an output port, and the port is claimed to be of a standard type such as RS-232, then the manufacturer shall certify that the port indeed meets that standard as commonly interpreted. When

connected to a personal computer, using the cabling and software supplied by the manufacturer, the output port shall transmit data in the manner claimed by the owner's manual (§5.12.1).

2.12.2 Switching Output. Some units may have a switching output, which can be used to trigger a camera, for instance. If a unit is claimed to have such an output, then it shall function as stated in the owner's manual when tested using the indicator box as described in §5.12.2.

2.12.3 Remote Control. A remote control or remote trigger is not required. If a model has a connector for remote control that is claimed to be of a standard type such as RS-232, the manufacturer shall certify that the port indeed meets that standard as commonly interpreted. When tested using the cabling and software supplied by the manufacturer, the remote control shall function as stated in the owner's manual. If more complicated proprietary remote control software is needed to fully exercise the remote control function, the lidar unit shall also function as claimed when additional features are tested with that software (§5.12.3).

2.12.4 Remote Trigger. If a remote trigger is supplied in lieu of or in addition to a remote control port, the lidar unit shall be triggered reliably using the switch box supplied by the manufacturer. Also the operation of the switch box shall meet the requirements specified in the owner's manual (§5.12.4).

2.13 Conducted Electromagnetic Interference

The susceptibility of the lidar device to conducted electromagnetic interference (EMI) from the vehicle alternator, vehicle ignition, air conditioner/heater motor, windshield wiper motor and typical police and citizens band transceivers shall be tested in accordance with §5.13. A lidar device powered by a battery pack and designed to also accept a nominal 12 V automotive system and adaptor as an optional source of power, shall also be tested for susceptibility to EMI (§5.13.1 through §5.13.4) utilizing this adaptor. During these tests, a blank target speed display shall not be considered an erroneous reading. Each lidar unit, when tested in accordance with §5.13, shall meet the following requirements:

2.13.1 Simulated Vehicle Alternator Interference. When subjected to a pulse signal 10 μ s to 20 μ s wide and 1 V peak to peak (p-p) amplitude (except for transition spikes) having maximum rise and fall times of 2 μ s (both excluding ringing), a ringing time no greater than 8 μ s, and a PRR between 200 pulses per second (pps) and 10,000 pps, the lidar unit shall not display any erroneous readings (§5.13.1).

2.13.2 Simulated Vehicle Ignition, Air Conditioner/Heater Motor, and Windshield Wiper Motor Interference. When subjected to a negative-ramp sawtooth signal having a 1 V p-p amplitude with a positive rise time back to zero of not more than 2 μ s, and having a frequency range of 200 Hz to 10 kHz, the lidar unit shall not display any erroneous speed readings (§5.13.2).

2.13.3 Simulated Police FM Transceiver Interference. When subjected to a 10 mW frequency modulated (FM) radio frequency signal in each police radio band, the lidar unit shall not display any erroneous speed readings (§5.13.3).

2.13.4 Simulated Citizen Band (CB) AM Transceiver Interference. When subjected to a 5 mW, amplitude modulated (AM) radio frequency in any of the CB channels specified in §5.13.4, the lidar unit shall not display any erroneous speed readings.

2.14 Radiated Electromagnetic Interference

The susceptibility of a lidar device to electromagnetic radiation from police FM or citizens band AM transceivers shall be subjected to field tests in accordance with §5.14. During these tests, a blank target speed display is not an erroneous reading. Each lidar device shall meet the following requirements:

2.14.1 Police FM Transceiver Interference. This test requires a police FM radio transceiver properly installed in a patrol vehicle. When tested in accordance with §5.14.1, the UUT shall display no erroneous readings when either the installed transceiver or a hand held police FM transceiver with integral antenna is operated within two meters of it.

2.14.2 Citizens Band (CB) AM Transceiver Interference. This test requires a CB AM transceiver properly installed in a patrol vehicle. When tested in accordance with §5.14.2, the UUT shall not display any erroneous readings when the AM radio is transmitting high frequency audio within two meters of it.

2.15 Speed Accuracy: Field Operation

When tested in accordance with §5.15, the lidar UUT must display the speed of a target vehicle within +2, -3 km/h (+1, -2 mph).

2.16 Vehicle Determination (Lidar Systems Only): Field Operation

Speeding violations shall be documented with a recorded image (or images) displaying the target vehicle in an appropriate position defined by the lidar system manufacturer. If the lidar system is used in unattended operation, the evidential image must show at a minimum, the target vehicle's license plate, speed, location, time, and administrating officer's identification. For comparison purposes, the manufacturer shall provide sample images.

2.16.1 Attended Operation. The ability of the lidar system to discriminate between target vehicles shall be demonstrated using the field-test methods described in §5.16.1.

2.16.2 Unattended Operation. If the lidar system is to be considered for unattended operation, the manufacturer of the system shall provide a secondary method for verifying that the evidential recorded image properly identifies the target vehicle and reflects this vehicle's true speed, as described in §5.16.2.

Section 3 - Test Conditions

3.1 Standard Conditions

Allow all measurement equipment to warm up until the system is stable enough to perform the measurement. Unless otherwise specified, perform all measurements under standard test conditions as follows:

3.1.1 Standard Temperature. Standard ambient temperature shall be between 20 °C (68 °F) and 30 °C (86 °F).

3.1.2 Standard Relative Humidity. Standard relative humidity shall be between 10 % and 85 %.

3.1.3 Standard Supply Voltage. For a device intended to operate from a nominal 12 V automotive system, the standard supply voltage shall be $13.6 \text{ V} \pm 0.1 \text{ V}$. For devices utilizing a battery pack, the standard supply voltage shall be a value specified by the manufacturer. A well-filtered electronic power supply capable of a voltage adjustment of $\pm 25 \%$ from the nominal should be used for laboratory testing and is recommended for other tests in place of the battery for safety and convenience. The standard supply voltage shall be applied to the input terminals of the dc supply cables (including all connectors and circuit protectors) as furnished by the manufacturer. Adjust the power supply to within 1 % of the specified standard voltage.

3.1.4 Special Instructions. Each time a test method requires that the lidar device interact with the target speed simulator, the lidar device shall also be connected to the standard supply voltage source and its optics properly coupled to the simulator.

Section 4 - Test Equipment

4.1 Test Equipment

The test equipment discussed in this section is limited to that equipment which is most critical in making the measurements discussed in this document. All other test equipment shall be of laboratory instrumentation quality. All test equipment shall be provided with instruction manuals.

4.2 Tripod

The tripod shall provide sturdy support and multi-axis adjustment, including a hinge-like joint that permits the lidar UUT to be tipped 90° to one side.

4.3 Test Range for Target Distance Feature

Two baselines shall be established, probably outdoors, to check the lidar unit's range feature at zero target speed (see fig. 2). Each baseline shall have at one end a fiducial mark by which the lidar unit can be positioned, and at the other end a well-anchored flat target perpendicular to the line of sight along the range. The target might be a building wall or a sign on a sturdy post. It will be helpful if the target is retroreflective. The exact target area and the working height of the lidar unit shall be decided and recorded first. Then, the distance shall be surveyed along the line of sight¹. One baseline distance shall be in the range of 6 m (20 ft) to 30 m (100 ft). The other baseline shall be at least 90 m (300 ft). (Note: a routine survey may give you horizontal distances only. That information cannot be used directly because the lidar device does not provide any means to measure the angle of elevation. Therefore, the baseline data must be complete enough to determine the heights above or below a horizontal reference plane of the targets and a UUT and allow the line-of-sight distance to be calculated to within 1 cm (0.4 in))

¹ If baselines are set up using electronic surveying equipment, a question may arise concerning the "certification" of the electronic distance-measuring device. There is no centralized program in the United States by which such equipment can be certified. It is a surveyor's responsibility to check his equipment against known monuments or other instruments, and to keep records. There is a national program for the establishment of calibration baselines; their use is optional. Two publications of the National Oceanic and Atmospheric Administration on this topic are: NOAA Technical Memorandum NOS NGS-8. Establishment of Calibration Base Lines by Dracup, Fronczek, Tomlinson, and Spofford, 1994, 17 pp., \$1.60; NOAA Technical Memorandum NOS NGS-10. Use of Calibration Base Lines by Fronczek, December 1977, reprinted 1980, 38 pp., \$2.80. Other information, including a list of baselines, is on the World Wide WEB at <http://www.ngs.noaa.gov/CBLINES/calibration.html>. Purchase of the publications can be arranged by email to info_center@ngs.noaa.gov, or by calling 301-713-3242, Monday – Friday, 7:00 am to 4:30 pm eastern time, or by mail to National Geodetic Information Branch, N/CG-17, 1315 East-West Highway, Room 9554, Silver Spring, MD 20910.

4.4 Long-Range Target

The long-range target consists of a rectangle of white retro-reflective material, centered on a circular black background, (see fig. 6). The retroreflective material shall be "engineering grade," Type I as specified in ASTM D 4956. The rectangle shall measure $300 \text{ mm} \pm 5 \text{ mm}$ horizontally, by $150 \text{ mm} \pm 5 \text{ mm}$ vertically. The background shall be matte black poster board, $610 \text{ mm} \pm 3 \text{ mm}$ in diameter. The retroreflective material may be affixed to the background with hook and loop material, (e.g., Velcro²) or otherwise.

4.5 Beamwidth Measurement Apparatus

The beamwidth measurement apparatus is an outwardly simple custom-made device that must meet the optical performance required in §5.6. Mechanical details may vary, so long as the optical performance is met.

4.6 Environmental Chamber

The environmental chamber or chambers shall produce air temperatures and humidities that meet the requirements of §2.7.1 and §2.7.2 while shielding the UUT from direct heating or cooling air currents. The temperature of the lidar device shall be measured with a thermometer that is separate from the sensor used to control the chamber air temperature and has an uncertainty no greater than $\pm 1 \text{ }^\circ\text{C}$ ($\pm 2 \text{ }^\circ\text{F}$). Likewise, humidity shall be measured with a hygrometer that is separate from the sensor used to control humidity and has an uncertainty no greater than $\pm 2 \%$.

4.7 Target Speed Simulator Based on Digital Delay Generator

The target speed simulator consists of a computer with IEEE-488 and counter-timer cards; a digital delay generator with an IEEE-488 interface-bus option; a receive-send module to trigger the delay generator and generate a return laser flash; IEEE-488 bus, 50 Ω coaxial and miscellaneous cabling; and the software program VS.EXE that was written at NIST.

The simulator must respond to the periodic flashes from the lidar UUT and return laser flashes with properly calculated delays. The simulator must simulate speeds from 0 km/h to 320 km/h (0 mph to 200 mph), approaching and receding. The speed of a simulated approaching vehicle should be treated as positive; the speed of a receding vehicle should be considered negative.

The simulator shall be based on a speed of light in air of 299,705,663 m/s. This value is correct at zero elevation and $T = 0 \text{ }^\circ\text{C}$. Changes in temperature and pressure will seldom affect the speed reading by more than one part in 10^4 . The error will be in the motorist's favor for temperatures and elevations higher than the reference conditions

² Certain materials are identified in this paper in order to adequately specify the experimental procedure. Such identification does not imply recommendation or endorsement by the National Institute of Standards and Technology, nor does it imply that the materials are necessarily the best available for the purpose.

4.8 Computer

The computer should be PC-compatible based on a 486 chip and have an IEEE-488 bus-interface card. This will permit using the software that NIST can supply to run on a DOS operating system.

4.9 Counter-Timer Interface Card

The counter-timer interface card functions primarily to determine the pulse repetition rate of the lidar UUT. It does not resolve the delay times generated by the digital delay generator. The card that has been used has a 5 MHz frequency source and a programmable timing chip with 5 separate 16-bit counters.

4.10 Digital Delay Generator

The digital delay generator must have the following characteristics:

4.10.1 Bus Reprogrammable - accept reprogramming of the delay time from the digital computer by a means such as the IEEE-488 interface bus.

4.10.2 Reprogramming Speed - accept reprogramming in less than 2.5 ms, so that the computer hardware and software plus the digital delay generator can simulate a moving target at lidar unit's PRRs up to 390 Hz.

4.10.3 Delay Ranges - generate delays ranging from $t_{\text{base}} + 0 \mu\text{s}$ to at least $t_{\text{base}} + 5 \mu\text{s}$, where t_{base} is a fixed delay relative to an external trigger of no more than 100 ns. The delay must be settable with a precision of at least 50 ps, and have an rms jitter of no more than 100 ps.

4.11 Pulse Generator

The pulse generator shall be capable of producing 10 V p-p across a 50 Ω load impedance, with rise and fall times of less than 1 μs and PRRs of 200 pps to 10,000 pps.

4.12 Sawtooth Wave Generator

The sawtooth wave generator shall be capable of producing 10 V p-p across a 50 Ω load impedance. It shall also be capable of producing a sawtooth waveform that has a negative going ramp and a positive-going trailing edge with a rise time of less than 1 μs . It shall be frequency adjustable over a range of 200 Hz to 10 kHz.

4.13 Pulse-Sawtooth Coupling Circuit

Injection of pulse and sawtooth waves into the power line of the UUT requires the circuit of figure 3. In the prototype, the capacitor was 10 $\mu\text{F} \pm 10\%$, 200 V dc. The inductor had an iron core; it was in fact the secondary of a filament transformer whose primary circuit

was open. The inductor's impedance, given by $Z = V_{\text{rms}}/I_{\text{rms}}$ with an applied sine-wave voltage, varied from 45.8 Ω at 200 Hz to 309 Ω at 10 kHz. Its inductance, determined by $L = Z/(2\pi f)$, varied from 36.4 mH at 200 Hz to 4.9 mH at 10 kHz. The inductor used must have an impedance of at least 40 Ω over this frequency range.

4.14 FM Signal Generator

The FM signal generator shall be capable of producing 20 mW output power at frequencies from 30 MHz to 500 MHz and shall have an audio frequency modulation variable from 500 Hz to 5 kHz, a 50 Ω output impedance, a maximum standing-wave ratio of 1.2, and a variable output level. It shall also have a deviation meter or calibrated control for determining the peak frequency deviation with an uncertainty no greater than 10 %.

4.15 AM Signal Generator

The AM signal generator shall cover the 25 MHz to 30 MHz frequency range, be capable of producing at least 20 mW output power with 99 % modulation depth over frequencies from 500 Hz to 5 kHz, have a 50 Ω output impedance, and have a maximum standing-wave ratio of 1.2. The generator should include a digital frequency counter having an uncertainty no greater than 1 part in 10^6 and a monitor or calibrated control for determining the modulation depth with an uncertainty no greater than 10 %. If an integral frequency counter is not provided, a separate frequency counter having the required accuracy shall be provided.

4.16 Line Impedance Stabilization Network (LISN)

The LISN, constructed as in figure 5, serves to couple the signal from the radio-frequency signal generator into the power line of the UUT, while the UUT is also receiving its power from the dc supply.

4.17 RF Power Meter

The power meter shall have 50 Ω feed-through detectors for measuring both the forward and reflected power over a frequency range of 20 MHz to 500 MHz. It shall have the ability to handle powers up to 50 mW with an uncertainty of no greater than 10 %.

4.18 Slide Whistle

The slide whistle, a wind instrument with a notched hollow tube and a variable displacement, shall be capable of producing audio frequency notes from 500 Hz to 3 kHz.

4.19 Oscilloscope

A digital sampling oscilloscope (DSO) is required for routine setup and adjustment of the simulator (see fig. 1) and for detailed verification that the simulator is working

correctly. It shall have an analog bandwidth of at least 500 MHz and a minimum sampling rate of at least 2 gigasamples/sec (2×10^9). It shall have at least two input channels. Each channel shall have 50 Ω input impedance and an auxiliary high-impedance probe. The DSO shall have automatic measurement capability for such parameters as the interval between pulses, amplitude, and frequency. It shall have Fast Fourier Transform capability. It shall have a repetitive single-shot mode which can trigger on one pulse, store 2000 or more points on two channels, then repeat when a new trigger occurs after 2 ms so that a train of 80 or more two-channel recordings is made. When operating in repetitive single-shot mode, it shall record the time of each trigger; for this purpose, the first trigger may be taken as time = 0.0, or time may be recorded as clock time (year, month, day, hour, minute, second), so long as the trigger times can be retrieved to a precision of 0.1 ms or less.

Section 5 - Test Procedures

5.1 (Reserved)

5.2 (Reserved)

5.3 Labeling and Operation Tests

With the lidar unit in hand, the test engineer shall review the instructions and the markings on the controls to verify that the controls operate as explained in the manual and consistently with their markings. The simulator or normal traffic may be used for input data. It is permitted for controls to have secondary functions beyond those marked; in these cases, there is a particular obligation for the manual to be written in plain English and to describe the use of the controls accurately.

While it is impossible for this test to be exhaustive, the test engineer shall look for:

- (a) controls that are unmarked, or marked in a misleading way;
- (b) modes of operation that are not documented;
- (c) misleading labels appearing in an alphanumeric display; and
- (d) lack of clarity in the manual, including possible typographical errors.

No misleading wording is permitted on the control panel and display, or in the manual. If an undocumented mode does turn up, such as an engineering test mode for instance, the resulting display shall be clearly different from the display in normal speed-measurement mode.

5.4 Range Accuracy

This test applies only to the accuracy of measurements of the distance to stationary targets. Target ranging shall be checked on the two measured baselines. The reference plane on the lidar unit is the front surface (the surface with the lenses) unless the manufacturer has clearly defined a different reference (see fig. 2). Set the lidar unit at the predetermined height (§4.3) and aim it at the correct target area. If the surveyed distance is not an integer number of meters or feet, corresponding to the system of units of the lidar device, make an auxiliary mark a fraction of a meter (or foot) forward of the fiduciary mark so that the range becomes an integer number of units. Repeatedly record the target range or error indication until five range measurements are recorded. All five readings must be correct to a tolerance of ± 0.3 m (± 1 ft). Perform this test and calculate the arithmetic mean of the readings for each of the pre-surveyed baselines.

5.5 Long-Range Test

Elevate the long range target (see fig. 6) so that its center, as seen from the lidar UUT, is at least 2 m above the ground or other obstacle. The background should be sky. Determine the greatest range at which the lidar unit can measure the distance to the target. Pay attention to the beamwidth of the UUT and the target's clearance from the ground; be sure that the UUT is ranging to the target and not something else. If a range

exceeding 300 m (1000 ft) has been measured and conditions do not permit the UUT to be backed farther away, the test may be stopped. Record detailed observations as the lidar operator moves back from the target, including all distances at which the UUT obtained range measurements and the reason for stopping the test.

5.6 Beam Characteristics Test

Set up the apparatus as illustrated in Figure 7. Note that this figure is not drawn to scale but is dimensioned to verify beam alignment, range accuracy, and beamwidth. Mount the lidar unit under test (UUT) upright on a tripod with the laser beam parallel to the ground (floor) and at the same elevation as the center points of the targets. The tripod mount shall permit the UUT to be rotated so the center line of the laser beam can be aimed at the center point of each target. To facilitate aligning the laser beam with the target, a small flashlight may be held just above the target. The flashlight must be removed before the test readings are taken. A 60 inch carpenter's level may be used to help align the front of the UUT with the reference mark.

5.6.1 Beam Alignment.

5.6.1.1 *Horizontal.* Slowly sweep the beam horizontally across target TC and observe that the range of TC is displayed only when the target is in the reticule of the sight, indicating lateral alignment.

5.6.1.2 *Vertical.* Rotate the UUT on its side on the tripod, so that it is at a right angle to its normal position. Repeat the process to verify vertical alignment.

5.6.2 Range.

Aim and record the distances to each of the three targets: TL, TC and TR. Repeat until ten range measurements have been recorded for each target. Verify that the UUT is capable of measuring and displaying the correct range to each target.

5.6.3 Target Discrimination.

5.6.3.1 *Horizontal.* Carefully sight the UUT at the space between TL and TC to demonstrate that the lidar beam is slender enough to pass between the targets without causing a reflection and range reading from either target. Repeat for targets TR and TC.

5.6.3.2 *Vertical.* Turn the UUT on its side on the tripod mount and repeat the procedure to verify that the beamwidth requirement is also satisfied in the vertical plane of the UUT.

5.7 Environmental Tests

5.7.1 Operational Temperature Test. Choose three speeds within the capability of the UUT and store them in a file for use by the simulator software as a "Standard Speed Series." (The speeds should be integer values in the UUT native system of units.) Place the UUT, with the power off, in the environmental chamber and adjust the chamber to the required low temperature, $T_{d_{Low}} \pm 2 \text{ }^\circ\text{C}$ ($\pm 3.6 \text{ }^\circ\text{F}$). Allow the UUT to reach thermal equilibrium and maintain it at this temperature for 30 min. Prepare the

simulator hardware and software so it is ready to run a test. Use protective gloves and remove the UUT from the environmental chamber. Connect the UUT to the standard supply voltage, turn it on, and optically couple it to the simulator. Measure the PRR and then test the UUT at the three simulated speeds. Work quickly, as frost may be forming on the external lens surface. Perform the high temperature test during the same day to dry out the unit.

A simulator test should remain valid despite a thin layer of frost. If the UUT fails to read the simulated speed accurately, repeat the test. The UUT shall meet the requirements of §2.7 within 15 min of operation. Any external frost in itself is not an intended feature of this test, and if it is possible to reduce ambient humidity, this may be done.

Repeat the test just described at the required high temperature, $T_{d_{High}} \pm 2 \text{ }^{\circ}\text{C}$ ($\pm 3.6 \text{ }^{\circ}\text{F}$). In the high-temperature case, energize the UUT when it is removed from the chamber, but wait 2 min before performing any measurements, including the test of PRR.

If the UUT is a lidar system, then repeat the test just described at the required low temperature, $T_{s_{Low}} \pm 2 \text{ }^{\circ}\text{C}$ ($\pm 3.6 \text{ }^{\circ}\text{F}$).

If the UUT is a lidar system then repeat the test just described at the required high temperature, $T_{s_{High}} \pm 2 \text{ }^{\circ}\text{C}$ ($\pm 3.6 \text{ }^{\circ}\text{F}$).

5.7.2 Operational Humidity Test. Place the UUT, with the power off, in a humidity chamber. Adjust the relative humidity to a minimum of 90 % at 37 °C (99 °F) and maintain the UUT at these conditions for at least 8 h. Remove the UUT from the chamber and bring it quickly to the simulator. If the UUT is a lidar system, wait for the UUT to cool to $T_{s_{High}}$. Connect the UUT to the standard supply voltage, then wait 2 min before performing any measurements. The UUT shall meet the requirements of §2.7 within 15 min of operation.

5.8 Low Supply Voltage Indicator Test

A simple connection box, as shown in figure 8, will permit meters to be connected for measurement of voltage and current. Comparison with figure 3 will show that this can be the same box used to inject the pulse and sawtooth signals.

Connect the lidar UUT to the adjustable supply voltage and properly couple its optics to the target speed simulator. Switch the UUT on and let it warm up for 2 min at its standard supply voltage. Set the system to consume maximum power. Set the target speed simulator to simulate a vehicle moving at 110 km/h (70.0 mph). Measure the simulated speed with the lidar unit. Decrease the lidar unit's supply voltage by 0.2 V and again measure the simulated speed. Continue to decrease the supply voltage and measure simulated speed until the low voltage alert is activated. Record the supply voltage level. Send each reading to the computer file, annotated by the voltage at which it occurs. No erroneous speed reading should occur. Increase the supply voltage until the low voltage indicator is deactivated, and again measure the simulated speed to verify that the UUT reads 110 km/h (70.0 mph).

Also, for a battery powered lidar device designed to accept a 12 V automotive adapter, verify that when using this adapter the device works properly down to its low voltage alert level. The low voltage alert levels are specified in §2.8.

5.9 Supply Voltage Tolerance Tests

Use the setup as in the previous section with a meter to monitor the supply voltage to the lidar UUT. Determine the working voltage range according to §2.9.

5.9.1 Pulse Repetition Rate. For units capable of a fixed PRR, set the simulator to measure PRR. Step through voltages as in §5.8, reaching the high and low limits according to §2.9 while noting the voltage and PRR. Be sure to record all digits of the PRR. The PRR shall not vary by more than 0.1 % from its value at standard supply voltage.

5.9.2 Range and Speed. In this part, the simulator software can be used to record the data. Prepare a table of distance-speed combinations according to the approach in §5.11. Set the simulator for normal speed simulation, including the description of the UUT. Next step through the voltage range as in §5.9.1, setting a different distance and speed at each voltage step. The UUT shall not display any erroneous speed readings. A blank display is not considered an erroneous reading. If a blank occurs, the test must be repeated, and an accurate non-blank speed must be obtained at each step.

5.10 Speed Display Tests

5.10.1 Display Readability. Establish a simulated target speed and verify that the display is clearly readable when used as intended by the manufacturer.

5.10.2 Speed-Display Lock. For convenience, these tests may be performed in conjunction with the display clear test of §5.10.3. The lidar device must have one condition under which the display is intended to lock; such as "as soon as a valid target is acquired after the press of the trigger" or "when the trigger is released." Verify that the display locks under the specified condition and not under other circumstances.

5.10.2.1 *Valid-Target Lock*. If the display locks as soon as a valid target is acquired after the press of the trigger, lock to a simulator speed setting, and then while the display is locked change the simulator's speed setting. Verify that the reading does not change.

5.10.2.2 *User-Initiated Lock*. If the display locks upon an action by the user, such as releasing a trigger, clear the display and establish a simulated target. Activate the lidar unit, but stop one step short of the step at which the display is intended to lock. For instance, if the display is intended to lock upon release of the trigger, squeeze the trigger and hold it down. Now turn off the simulated target, wait three seconds, and then take the next step, such as releasing the trigger. Verify that the speed display reads blank or zero.

5.10.3 Display-Clear Function. Connect the lidar unit to the target simulator, energize it, and establish a simulated target. Press and release the trigger, locking in a speed reading. Turn off the simulated echo. Press and release the trigger a second time. The display should clear. Now operate one of the control switches (speed, range, display intensity, timing mode, etc.) and verify that the display remains clear. Start over by reading the nonzero speed of a simulated target and then repeat these steps for each control switch on the UUT. In the absence of a (simulated) target, no sequence of switch operations shall cause a nonzero speed to be displayed after the display has been cleared.

5.10.4 Internal-Circuit-Test Function. Perform the internal circuit test according to the manufacturer's instructions. This may simply require the lidar unit to be switched off and on. Verify that only the correct readings are displayed, and that all readings are cleared automatically when the test is completed. Repeat the internal circuit test and attempt to actuate the speed lock while the readings are displayed. Verify that no nonzero reading is retained by the display.

5.10.5 Low-Speed and High-Speed Display Limits. Let "slow limit" be 16 km/h (10 mph) or the lowest speed at which the manufacturer states that his device will operate, whichever is lower. Let "fast limit" be 320 km/h (200 mph) or the highest speed at which the manufacturer states that the device will operate properly, whichever is higher. By definition, these limits are positive or zero. Set the simulator to each of the following conditions and record data. An accurate non-blank reading should be obtained in each case.

- (1) Initial distance = 61 m (200 ft); speed = - (slow limit)
- (2) Initial distance = 302 m (990 ft); speed = (slow limit).
- (3) Initial distance = 61 m (200 ft); speed = - (fast limit).
- (4) Initial distance = 302 m (990 ft); speed = (fast limit).

5.10.6 Audio Tones and Error Messages. It is not required for the lidar device to emit audio signals. If it does make sounds, test it on the simulator or simply beside a road, and generate a mixture of valid readings and error indications.

If necessary, turn on the audio signal. Make written notes of the relationship between the display and the sounds generated. Then continue to generate valid and invalid readings and verify that the relationship is consistent.

5.10.7 Speed Monitor Alert. Verify that the lidar device does not have a speed monitor alert.

5.11 Speed Accuracy: Laboratory Simulation Tests

5.11.1 Smoothly Moving Target. Begin by noting the stated limitations of the simulator and the UUT. Determine the range of speeds and distances that are available both to the simulator and to the UUT and, thus, can be used for testing.

Record range and speed from the display of the UUT. The simulator software will automatically record the simulated range and speed. No erroneous speed readings shall occur. A blank display or an error message is not an erroneous reading; if the UUT gives a blank display or an error message, repeat the test and adjust the simulator if necessary. It is required for the UUT to give a reading at all settings tested within the working range.

Distance, ft	Speed, mph
4000	200
100	-200
2000	20
2000	-20
800	70
800	65
1000	60
600	55
300	-55
300	25
300	-30
500	35
500	-35
200	-65
100	-80
400	80
400	-85
600	85
600	90
600	-90
500	73
500	77
300	-40
300	44
300	47
333	52
222	-54
777	100
777	97
777	111

5.11.2 Smoothly Moving Target with Sawtooth Perturbation. A lidar unit can potentially read an erroneous speed if successive laser pulses are not all reflected from the same part of the same target vehicle. It is the user's job to hold the laser device steady, but there is also a need for the instrument to reject bad data based on clues contained in the data set. That is, raw data of range versus time should ideally plot as a straight line; when the raw data deviate from straightness, the speed derived from the data is suspect, and it should not be displayed. The exact criteria for rejecting suspicious data have been a matter of engineering development and are proprietary to the lidar manufacturers. This section will verify that the UUT has some ability to reject suspicious data.

The simulator software has a perturbation feature that permits a periodic disturbance to be added to the normal simulation of a target moving at constant speed. The user must describe the perturbation in an ASCII file, rather than interactively. The file specifies the distance as a function of time by an ordered list of pairs beginning at time 0.0 s. The unit of distance may be chosen as feet or meters. The program interpolates the function linearly between the given points and then applies the appropriate perturbation to the delay of the return laser pulse. The perturbation has a period equal to the interval of the given function. The standard perturbation is defined by the four points listed below. This perturbation is based on a realistic view of what bad data may look like, but it is by no means a basis for writing an error-trapping algorithm.

Time, s	Distance, ft
0.0	0.0
0.010	0.0
0.012	5.0
0.200	0.0

If entered in just this form, the perturbation is null for 10 ms after the first pulse of the UUT. It then jumps to about 5 ft in 2 ms and ramps back down to zero by the end of the total time interval of 200 ms. It immediately repeats. The test laboratory may optionally shift the perturbation cycle in time. If the perturbation is shifted in time, the total time interval still must be less than the period between laser pulses from the UUT. In general, it might take five points to redefine the function in time-shifted form, and a small change in the function may result because of the way the software splices the end of one cycle onto the beginning of the next. In any event, the software allows the operator to review the net perturbation exactly as it will be applied, pulse by pulse.

In testing with perturbed data, the expected result is "no reading," or perhaps an error message. The procedure that follows includes frequent control experiments to verify that all the wires, switches, and optical alignment are correct, and that an occurrence of "no reading" is indeed a valid rejection of invalid data.

Prepare a list of at least 12 different distance-speed simulator settings similar to that in §5.11.1. Start the simulator and follow its top-level menu to write the PRR, time, and a description of the experiment into a header for a results file. Test the UUT at the first setting, with the perturbation OFF. Record the reading. If no reading is obtained, adjust the setup until reliable readings are obtained; then record one reading. At the same distance-speed setting, and at three other settings, record data with the perturbation ON. Although the simulator software will automatically note that the perturbation is on, the detailed perturbation file(s) shall be kept with the data and printed out for complete documentation. Using the next distance-speed setting, record another reading with the perturbation OFF. Again verify that the simulator and UUT are working. Then, with the perturbation ON, record data at that setting and the next three. Repeat this process until the list of settings is used up. It may be convenient to select a different perturbation file after each grouping of five measurements. (See the previous discussion about shifting the time origin.)

No erroneous readings are permitted. A blank display or an error message is not an erroneous reading.

5.12 Auxiliary Equipment and Interface Tests

5.12.1 I/O Port. If the UUT has a computer I/O port, such as RS-232, use the information, software, and cabling supplied by the manufacturer to verify that the port is operational. That is, the lidar unit's I/O port should send data in the manner specified and in the sequence claimed. Exhaustively detailed testing is not required.

5.12.2 Switching Output. If the UUT has a switching output, use the information and indicator box supplied by the manufacturer to verify that the switching output functions as claimed. In a typical instance, the indicator LED shall go off and on in the expected way, and further checking of the circuit and the terminal voltage shall show that the output is sourcing or sinking a current at the times claimed.

5.12.3 Remote Control. If the UUT has a connector for remote control that is claimed to be a computer port of a standard type, use the information, simple software, and cabling supplied by the manufacturer to verify that the remote control function is operational. That is, the lidar unit's I/O port should receive data in the manner specified, and act on the commands issued. If more elaborate proprietary remote control software is sold for use with the UUT, test the functionality of that software with the unit. All functions tested should work as claimed, but testing need not be exhaustive.

5.12.4 Remote Trigger. If the UUT has a remote trigger function, test it with the information and switch box supplied by the manufacturer. Verify that the switch box triggers a measurement in the manner claimed, and that the circuitry of the switch box is consistent with the description in the owner's manual.

5.13 Conducted Electromagnetic Interference Tests

If the unit under test is intended to be connected to an external source of power, then connect the lidar unit to the simulator and to the other test equipment as shown in figures 1 and 3. Activate the UUT and verify that it is interacting with the simulator and correctly measuring the simulated speed.

In §5.13.1 and §5.13.2, the amplitude of the pulse or sawtooth wave must be set with a dummy load in place of the UUT. The dummy load is a 10 Ω resistor with a power rating of at least 20 W. [$V^2/R = (13.6 \text{ V})^2/10 \Omega = 18.5 \text{ W}$.] The dummy load may be removable, as indicated, or the output may be switchable between the dummy load and the UUT. In the prototype, the dummy load was made from a 10 Ω nominal resistor, with an adjustable tap; since the end-to-end resistance exceeded 10 Ω , the slider was set to give a resistance within 1 % of nominal. A high-impedance oscilloscope probe must be attached across the dummy load. With the dummy load in place, it will show somewhat distorted pulse and sawtooth waveforms. At the fast edges of the distorted waveforms, narrow transient spikes may appear. Although these transients may be an important potential source of interference, they are to be ignored in setting the peak to

peak amplitude of the waveforms. Figure 4 shows an oscilloscope display of a distorted pulse. "Markers" have been set on the oscilloscope to show the approximate baseline and top line of the waveform.

5.13.1 Simulated Vehicle Alternator Interference.

5.13.1.1 *Frequency Dependence.* Connect the pulse generator and the oscilloscope to the coupling circuit of figure 3. Set the generator's PRR to 200 pps, the pulse width to 10 μ s to 20 μ s, and the pulse amplitude to 1 V p-p or 7.5 % of the standard supply voltage in use (whichever is lower), as measured by the oscilloscope across the dummy load. Remove the dummy load from the coupling circuit and replace it with the lidar UUT. Establish a simulated target speed of 64 km/h (40 mph) and slowly vary the generator's frequency from 200 pps to 10,000 pps and back to 200 pps in convenient steps. Operate the UUT at 10 or more of these steps and record detailed data using the simulator software. Verify that no erroneous readings appear.

5.13.1.2 *Amplitude Dependence at 1500 pps.* Perform §5.13.1.1 using a constant pulse rate of 1500 pps while slowly varying the pulse amplitude from 0 to 1 V p-p or 7.5 % of the standard supply voltage in use (whichever is lower) and back to 0 V, as measured by the oscilloscope. Operate the UUT at five or more of these steps and record detailed data with the simulator software.

5.13.1.3 *Amplitude Dependence at 3100 pps.* Repeat §5.13.1.2 using a constant PRR of 3100 pps.

5.13.2 Simulated Vehicle Ignition, Air Conditioner/Heater Motor, and Windshield Wiper Motor Interference. Connect the sawtooth wave generator and dummy load in place of the pulse generator and lidar UUT. Set the generator's output frequency to 200 Hz and the waveform amplitude to 1 V p-p or 7.5 % of the standard supply voltage in use (whichever is lower) as measured by the oscilloscope across the dummy load. Remove the dummy load from the coupling circuit and replace it with the lidar UUT. Establish a simulated target of 64 km/h (40 mph) and slowly vary the generator frequency from 200 Hz to 10 kHz and back to 200 Hz. Operate the lidar UUT at 12 or more values of the sawtooth frequency, including 200 Hz and 10 kHz, recording data with simulator software. Verify that no erroneous readings appear.

5.13.3 Simulated Police FM Transceiver Interference.

5.13.3.1 *160 MHz.* Connect the lidar UUT and the FM signal generator to the line impedance stabilization network, as shown in figure 10, such that the rf signals are coupled onto the power line of the UUT, and establish a simulated target of 64 km/h (40 mph).

5.13.3.1.1 *Frequency Dependence.* Set the generator to an rf carrier frequency of 160 MHz with an output of 10 mW and no more than 1 mW of reflected power as measured by the power meter. Set the signal generator's frequency deviation (modulation width) to 5 kHz and vary the modulation frequency from 200 Hz to 10 kHz in convenient steps. Operate the UUT at 12 or more values of modulation frequency, including 200 Hz and 10 kHz, and record detailed data with the simulator software. Verify that no erroneous readings appear.

5.13.3.1.2 *Amplitude Dependence for FM Modulation.* Set the modulation frequency to a constant 1.5 kHz and vary the FM signal generator output power from 0 mW to 10 mW and back to 0 mW in convenient steps. Record data at 10 or more points with the simulator software. Change the modulation frequency to 3.1 kHz, and record detailed data at 10 or more points from 0 mW to 10 mW and back to 0 mW with the simulator software. Verify that no erroneous readings appear.

5.13.3.2 *40 MHz.* Repeat all of §5.13.3.1 for a carrier frequency of 40 MHz.

5.13.3.3 *460 MHz.* Repeat all of §5.13.3.1 for a carrier frequency of 460 MHz.

5.13.4 Simulated Citizens Band (CB) AM Transceiver Interference.

5.13.4.1 *Frequency Dependence.* Connect the AM signal generator to the line impedance stabilization network, as shown in figure 10, such that the rf signals are coupled onto the lidar unit's power line. Establish a simulated target of 64 km/h (40 mph). Set the generator to a frequency of 27 MHz with an output of 5 mW and reflected power of no more than 1 mW, as measured by the power meter. Adjust the generator modulation depth to 99 % and vary the modulation frequency from 200 Hz to 10 kHz. Operate the lidar unit and record data using the simulator software at 12 or more modulation frequencies, including 200 Hz and 10 kHz. Verify that no erroneous readings appear.

5.13.4.2 *Amplitude Dependence for 1.5 kHz Modulation.* Perform §5.13.4.1 using a constant modulation frequency of 1.5 kHz and vary the AM signal generator output from 0 mW to 5 mW and back to 0 mW. Operate the lidar unit and record data at 10 or more points, including the extremes of the power level.

5.13.4.3 *Amplitude Dependence for 3.1 kHz Modulation.* Perform §5.13.4.2 using a constant modulation frequency of 3.1 kHz.

5.14 Radiated Electromagnetic Interference Tests

In this test, the lidar device will be tested for potential interference from two types of vehicle-mounted transceivers, and from a hand held transceiver. The lidar shall be operated by a person either seated in either front seat of a patrol vehicle of the type normally used for law enforcement or standing close by that vehicle. This patrol vehicle shall be the same one containing the rf transceiver. In addition to the person operating the transceiver and slide whistle and the person aiming the UUT, it may be helpful to have an additional person to write down readings from the UUT as they show up in the display. It may also be possible to record the readings via a serial link to a computer; in this case, the software must be arranged so that the relevant data for each test are clearly labeled. It may be helpful to steady the lidar with a tripod or other support.

The patrol vehicle shall be located along side a straight road or test track and the UUT shall be used to measure the speed of a target vehicle that is at least 120 m (400 ft) away and traveling at a speed of approximately 80 km/h (50 mph).

When the slide whistle is used, it shall be blown very hard in order to generate strong overtones that modulate the rf carrier at audio frequencies higher than those of the fundamental notes.

5.14.1 Police FM Transceiver Interference Test.

5.14.1.1 *Patrol Vehicle Transceiver.* Run the patrol vehicle engine at idle. Activate the push-to-talk switch and use the slide whistle to generate audio that is coupled into the transceiver via the microphone. Blow the whistle hard and vary the slide position over the entire range while measuring the speed of the distant target vehicle with the UUT. Observe or record the readings from the UUT, looking for erroneous readings. Repeat two more times.

5.14.1.2 *Hand-Held Transceiver.* Turn off the FM transceiver and perform the test of §5.14.1.1 using a Hand-Held FM transceiver with an integral antenna and an output power of 2 W or more positioned at the patrol vehicle driver's location.

5.14.2 Citizens Band (CB) AM Transceiver Interference.

Mount a 4 W minimum output CB transceiver in a typical front seat location and install its antenna as recommended by the manufacturer; or use any vehicle which has a CB installed. Run the vehicle engine at idle. Switch on the CB transceiver, set it to channel 20, activate the push-to-talk switch, and use the slide whistle to generate audio that is coupled into the transceiver via the microphone. Blow the whistle hard and vary the slide position over the entire range while measuring the speed of the distant target vehicle with the UUT. Observe or record the readings from the UUT, looking for erroneous readings. Repeat for channels 1 and 40.

5.15 Speed Accuracy: Field Operation Test

5.15.1 Speedometer-Correction Factor. Establish a measured distance of at least 402 m (1320 feet) on an open, level location away from other moving targets. Drive the target vehicle over the measured distance at a constant speed, preferably using the vehicle's cruise control, and measure the elapsed time with a stopwatch while recording the speedometer readings. Repeat the procedure twice in each direction, maintaining the same speed for all four runs. Use the stopwatch to determine the target vehicle's average speed and use this speed to calculate the target vehicle's speedometer correction factor. The corrected speedometer reading shall be compared with the speed reading provided by the certified radar unit and that of the lidar UUT to determine the accuracy of the UUT.

5.15.2 Speed Test

5.15.2.1 *Power supply.* For this test, the UUT may be powered from a vehicle, a portable battery, or a power supply adjusted to the standard power supply voltage.

5.15.2.2 *Safety Considerations.* For safety reasons, the UUT may be mounted on a tripod or handheld and may be as far as 4 m (13 feet) from the centerline of the test roadway. The distance from the speed measurement region to the UUT shall at least be 20 times the UUT's offset from the center of the roadway. (If the UUT is 4 m (13 feet) to one side and 100 m (328 feet) downrange, the cosine effect will be less than 0.1%.) These distances shall be recorded. The distance of the UUT from the speed-measurement region may be measured with the UUT's range function, provided the range accuracy of the UUT has been previously established.

5.15.2.3 *Certified Radar Unit.* The certified radar unit shall be positioned in a manner similar to the lidar UUT. This radar unit should be used to obtain independent target-vehicle speed readings. These readings shall be recorded and compared to the UUT's speed readings of the target vehicle.

5.15.2.4 *Target Vehicle.* For each test run, drive the target vehicle through the measured test range at a constant speed. Test runs shall be performed with the target vehicle both approaching and receding from the UUT at speeds of approximately 32 km/h, 80 km/h and 112 km/h (20 mph, 50 mph and 70 mph). The driver of the target vehicle shall maintain the assigned speed before reaching and until after passing through the measured test range.

5.15.2.5 *Data Collected for Each Test Run.* For each test run, measure and record the following: 1) the elapsed time for the target vehicle to pass through the measured test range; 2) the exact distance of the measured test range; 3) the minimum, maximum and average speedometer readings; 4) the minimum, maximum and average radar readings; 5) the minimum, maximum and average UUT readings or a single reading for a lidar system; 6) any anomalies associated with the run.

Each certified radar speed reading on the target vehicle shall be recorded. The certified radar speed reading and the speedometer corrected speed reading shall be compared to determine the average speed of the target vehicle over the test course. This speed shall be used to compare with speed readings of the lidar UUT for overall speed accuracy.

5.16 Vehicle Determination (Lidar Systems Only): Field Operation

If requested by the lidar system manufacturer, test the unit for both attended and/or unattended operation.

Install and connect the supplied imaging equipment in accordance with instructions provided by the manufacturer. Insure the lidar system is oriented for the direction of enforcement, whether operating in the receding mode or approaching mode.

5.16.1 Attended Operation.

5.16.1.1 *Direction Discrimination.*

5.16.1.1.1 *Approaching Targets.* Place the lidar system in the approaching mode, if applicable, with a threshold speed of 35 mph. Drive an automobile at 50 mph through the laser beam in the approaching direction. Repeat, but drive the automobile in the opposite direction through the lidar system beam. The lidar system shall only record the approaching automobile or provide information indicating the target vehicle's direction of travel.

5.16.1.1.2 *Receding Targets.* Repeat the test with receding mode if applicable. The lidar system shall only record the receding automobile or provide information indicating the target vehicle's direction of travel.

5.16.1.2 *Speed Discrimination.*

5.16.1.2.1 *Approaching Targets.* Place the lidar system in the approaching mode, if applicable, with a threshold speed of 65 mph. Drive an automobile at 50 mph through the laser beam in the approaching direction. The lidar system shall not record the automobile. Repeat test a second time.

5.16.1.2.2 Receding Targets. Repeat the test with the lidar system with the receding targets. The lidar system shall not record the receding automobile. Repeat test a second time.

5.16.1.3 Multiple Vehicles.

5.16.1.3.1 Approaching Targets. Place the lidar system in the approaching mode, if applicable, with a threshold speed of 50 mph. Drive two automobiles at any speed slower than the threshold speed so that they are operating in different lanes and in close proximity to each other. The lidar system shall not record any speed.

5.16.1.3.2 Receding Target. Repeat the test with the lidar system in the receding mode, if applicable. The lidar system shall not record any speed.

5.16.2 Unattended Operation. Repeat the tests of §5.16.1 supplemented by the manufacturer's secondary method for verifying that the evidential image correctly identifies the target vehicle and its speed.

APPENDIX

**Table 1 - Minimum Performance Specifications for Lidar
Speed-Measuring Devices and Systems**

Performance Characteristic	Minimum Requirement	Section
Wavelength of pulsed laser*	Infrared	§1.3
Pulse repetition rate*	≤ 390 Hz	§2.2.12
Pulse repetition rate variation*	≤ 0.1 %	§2.2.12
Low supply voltage [†]	≤ 10.8 V	§2.8
Horizontal functional beamwidth	≤ 5 mrad	§2.6.3
Vertical functional beamwidth	≤ 5 mrad	§ 2.6.3
Display readability	Easily readable when used as intended	§2.10.1
Maximum low speed	16 km/h (10 mph)	§2.10.5.1
Minimum high speed	320 km/h (200 mph)	§2.10.5.2
Speed accuracy	+2 km/h, -3 km/h (+1 mph, -2 mph)	§2.11
Speed error trapping	Periodic sawtooth perturbation: 200 ms, 1.52 m (5 ft) peak	§2.11.2
Long Range	300 m (1,000 ft) minimum	§2.5
Range Accuracy	±0.3 m (±1 ft)	§2.4
Vehicle Determination	Documented with a recorded image (or images)	§2.16

* Not a functional requirement, but relates to the present limitations of the test instrumentation, in particular the target speed simulator. The manufacturer may be required to provide test equipment (§2.1) if these specifications are exceeded.

[†] Applicable for lidar units that can be powered from a nominal 12 V automotive system. Self-powered units have a different minimum specification for low supply voltage (§2.8).

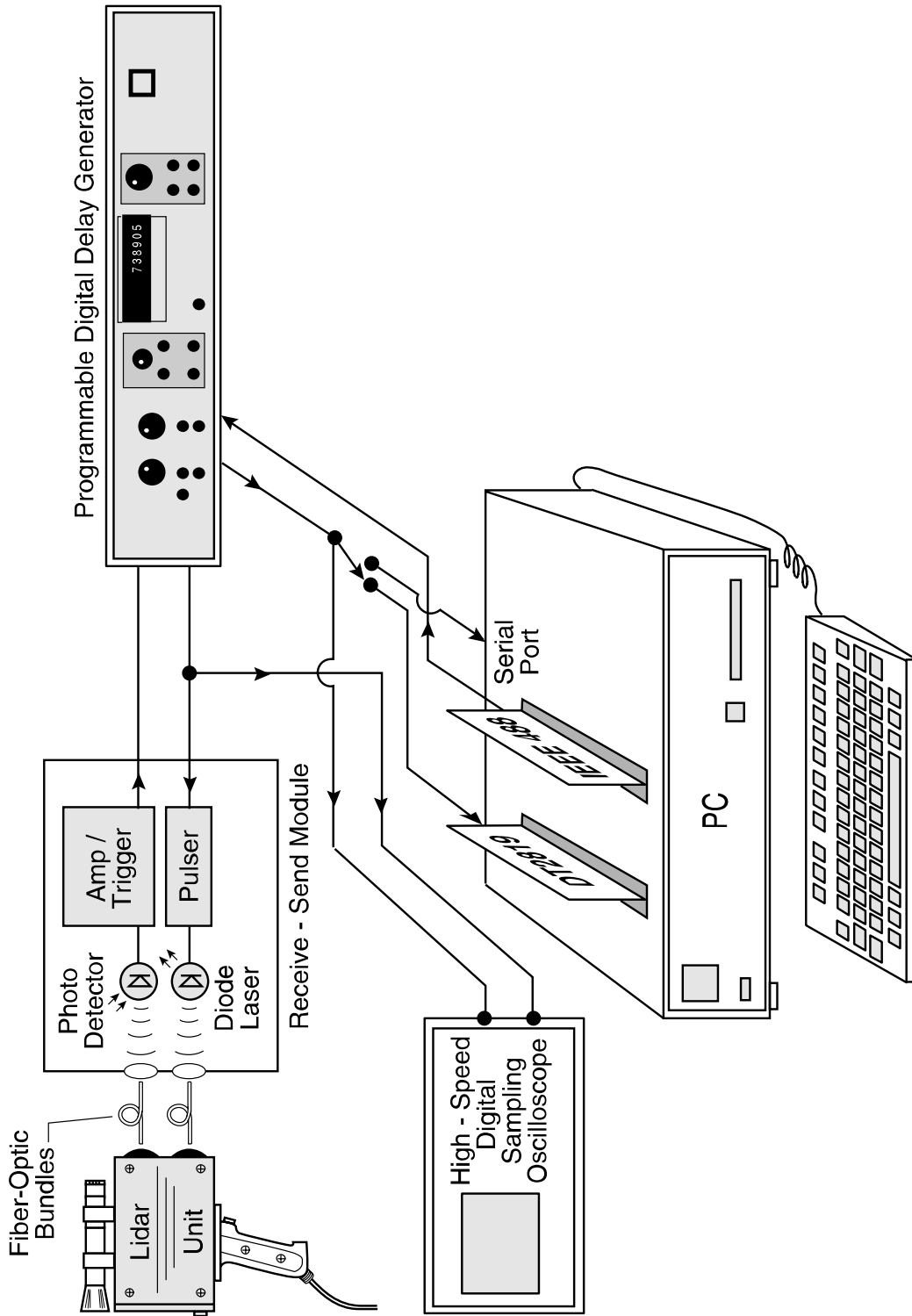

Figure 1. Block diagram of the target simulator

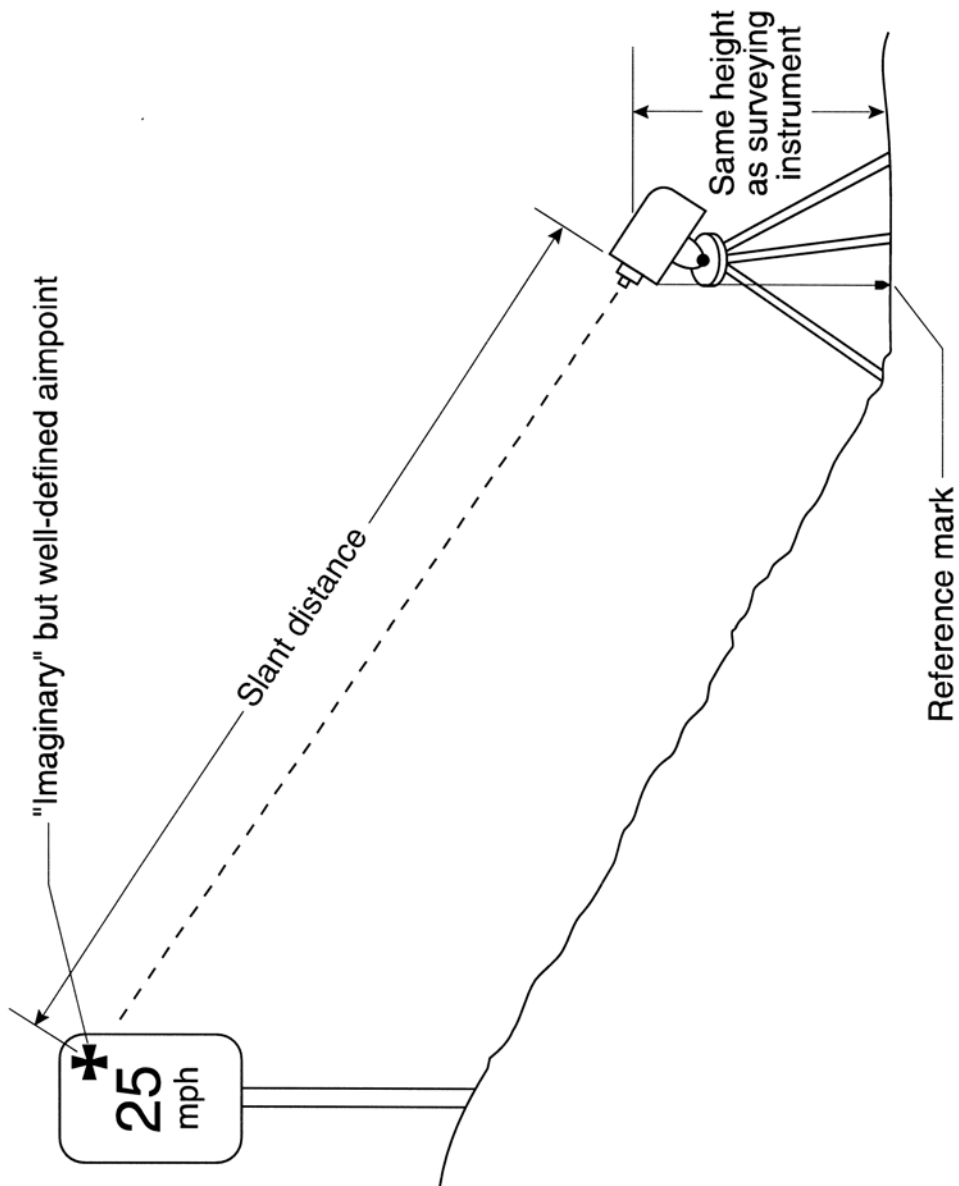

Figure 2. Schematic of the test range for the target distance feature

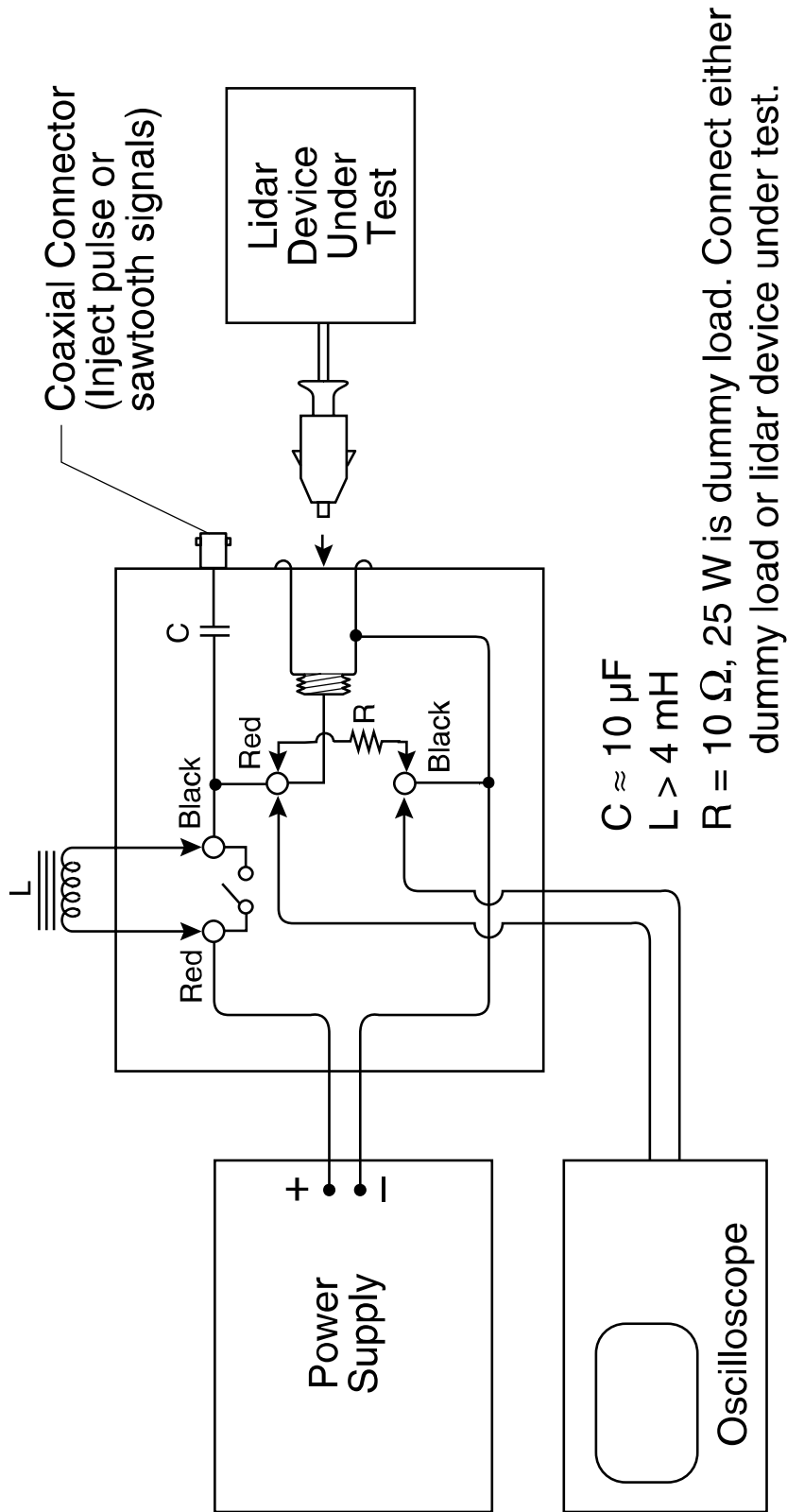

Figure 3. Block diagram of the pulse-sawtooth coupling circuit

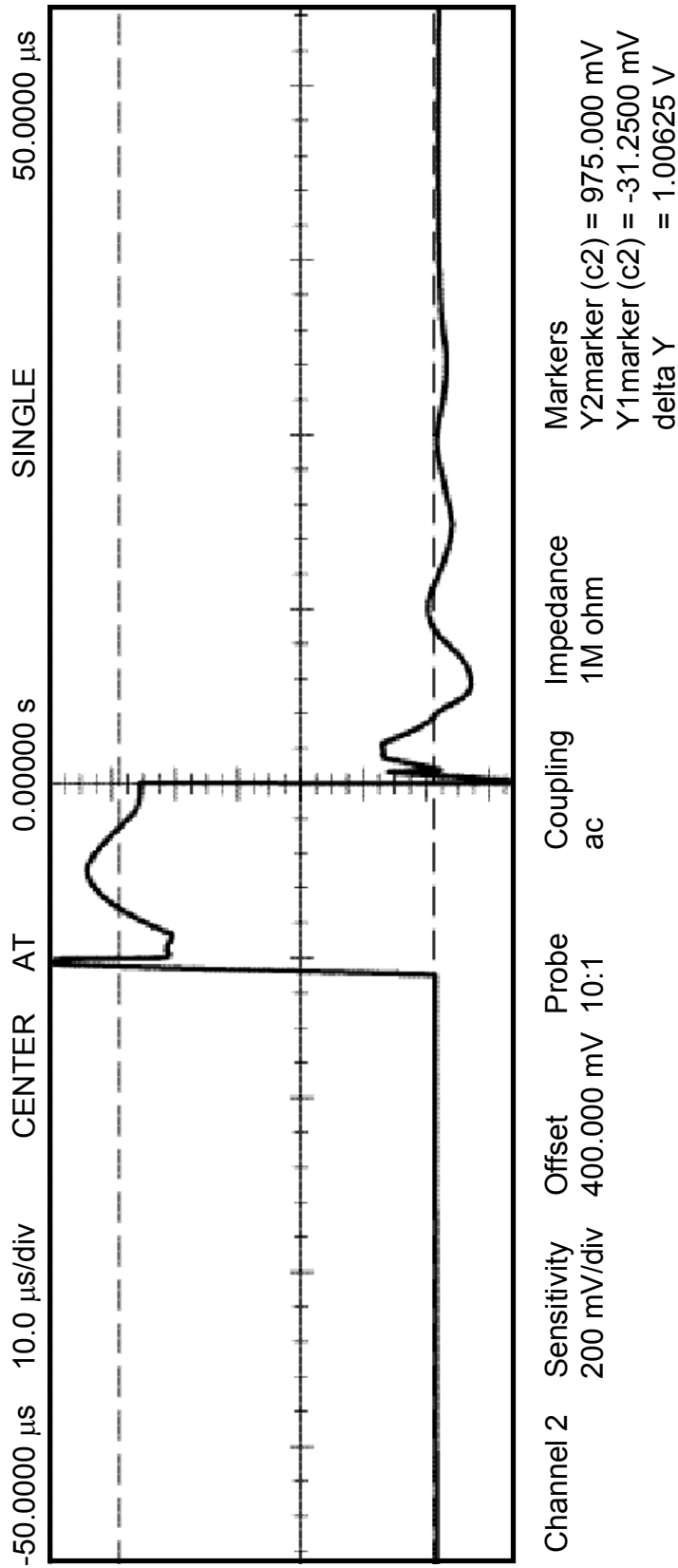

Figure 4. Oscilloscope of a rectangular pulse, coupled through the circuit of figure 3 into the 10 Ω dummy load

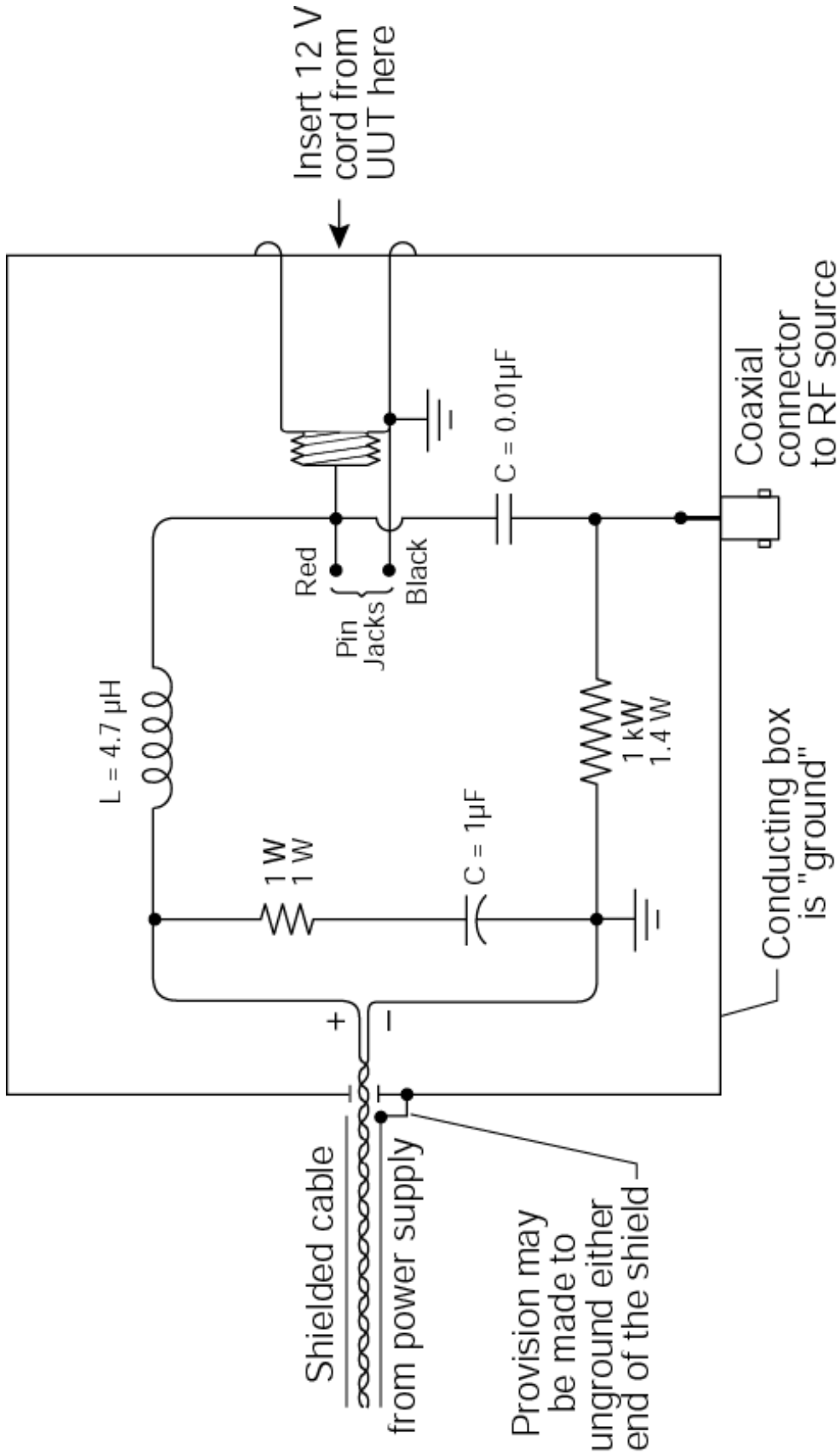

Figure 5. Block diagram of the line impedance stabilization network (LISN)

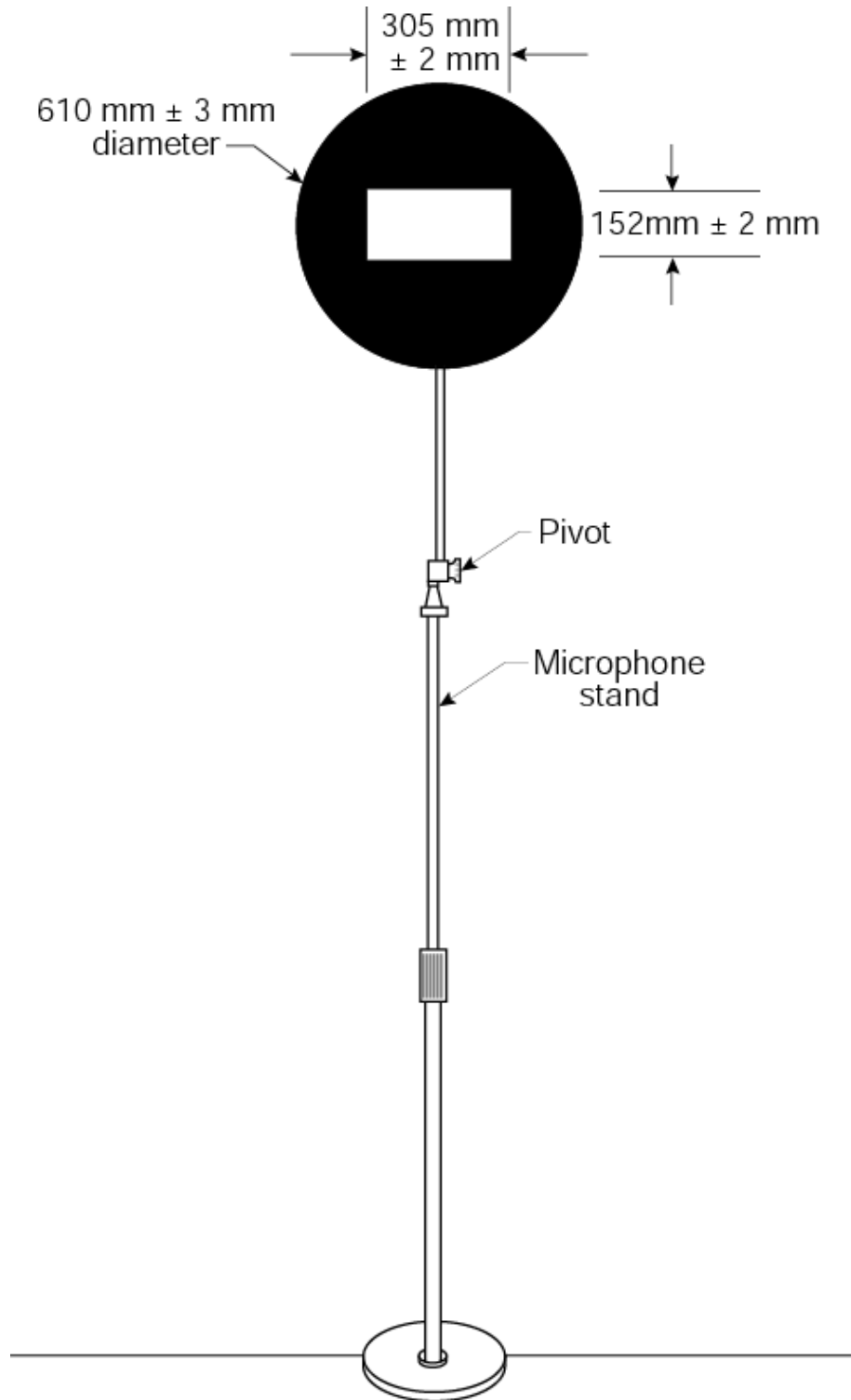

Figure 6. Schematic of the long-range target apparatus

Measured Distances

D1 = 202.5 ft

D2 = 200.5 ft

D3 = 204.5 ft

D4 = 12.0 in

D5 = 12.0 in

Targets

The targets are flat disks of retro-reflective material

TL = Target Left = 50 mm = 1.97 in Diameter

TC = Target Center = 30 mm = 1.18 in Diameter

TR = Target Right = 50 mm = 1.97 in Diameter

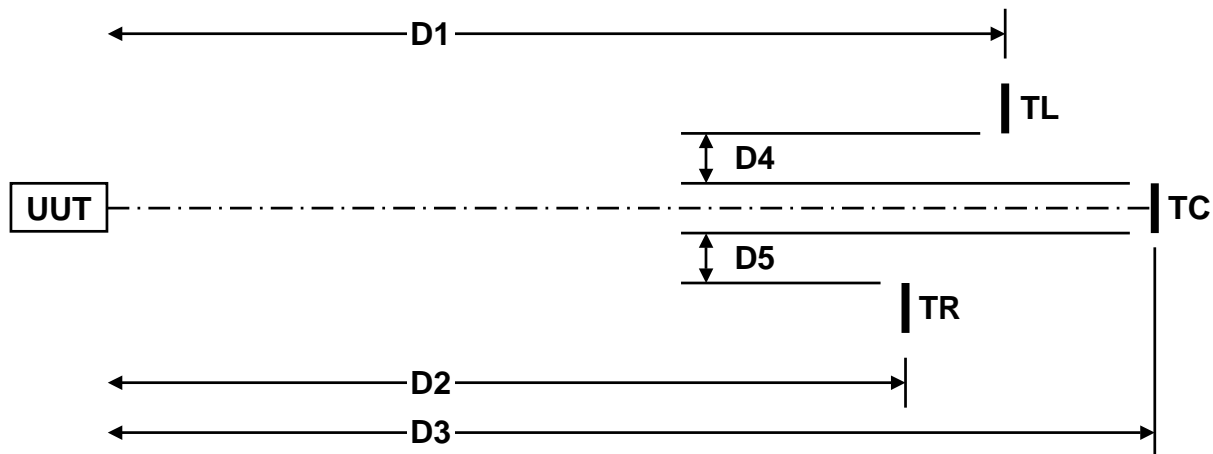
**Notes:**

1. D1, D2, D3 are measured within approximately ± 1 in.
2. D4 and D5 are measured within ± 0.1 in.
3. The diameters of the targets constructed within approximately ± 1 mm.
4. The axes perpendicular to the plane of the targets are parallel.
5. The center points of the targets are $64 \text{ in} \pm 0.1 \text{ in}$ above the ground (floor).

Figure 7. Schematic of the beam characterization apparatus

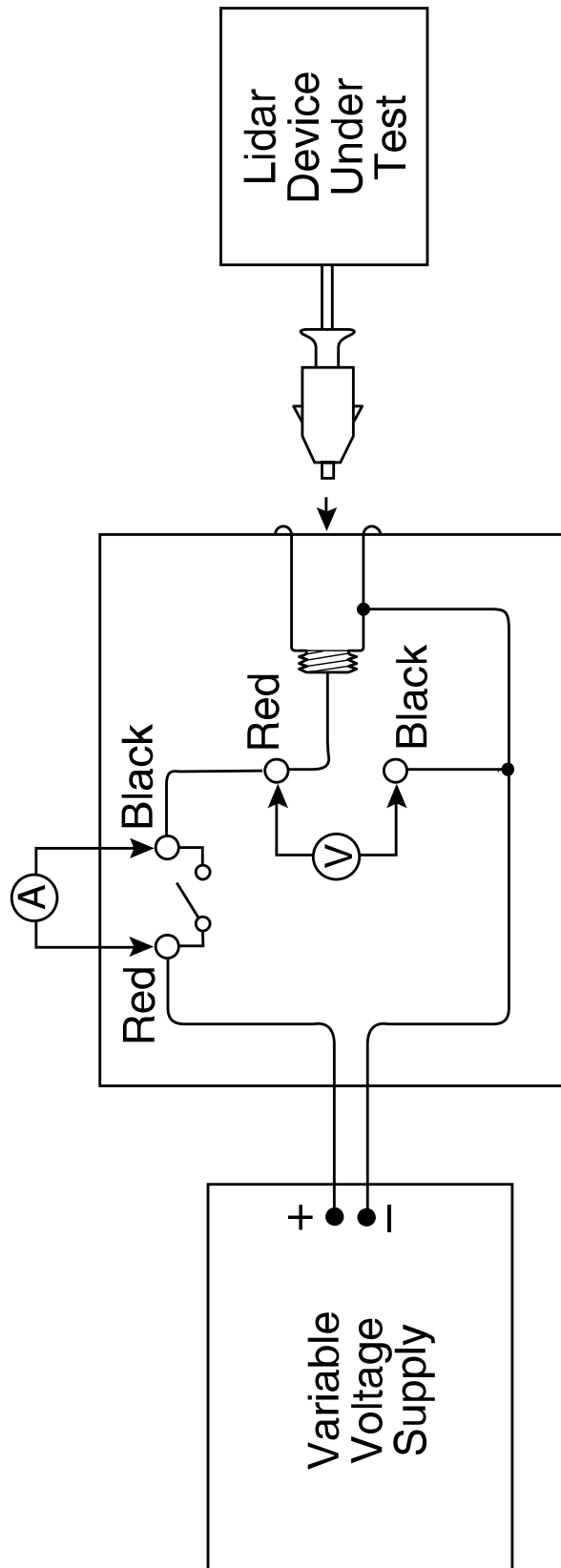

Figure 8. Block diagram of the low voltage test circuit

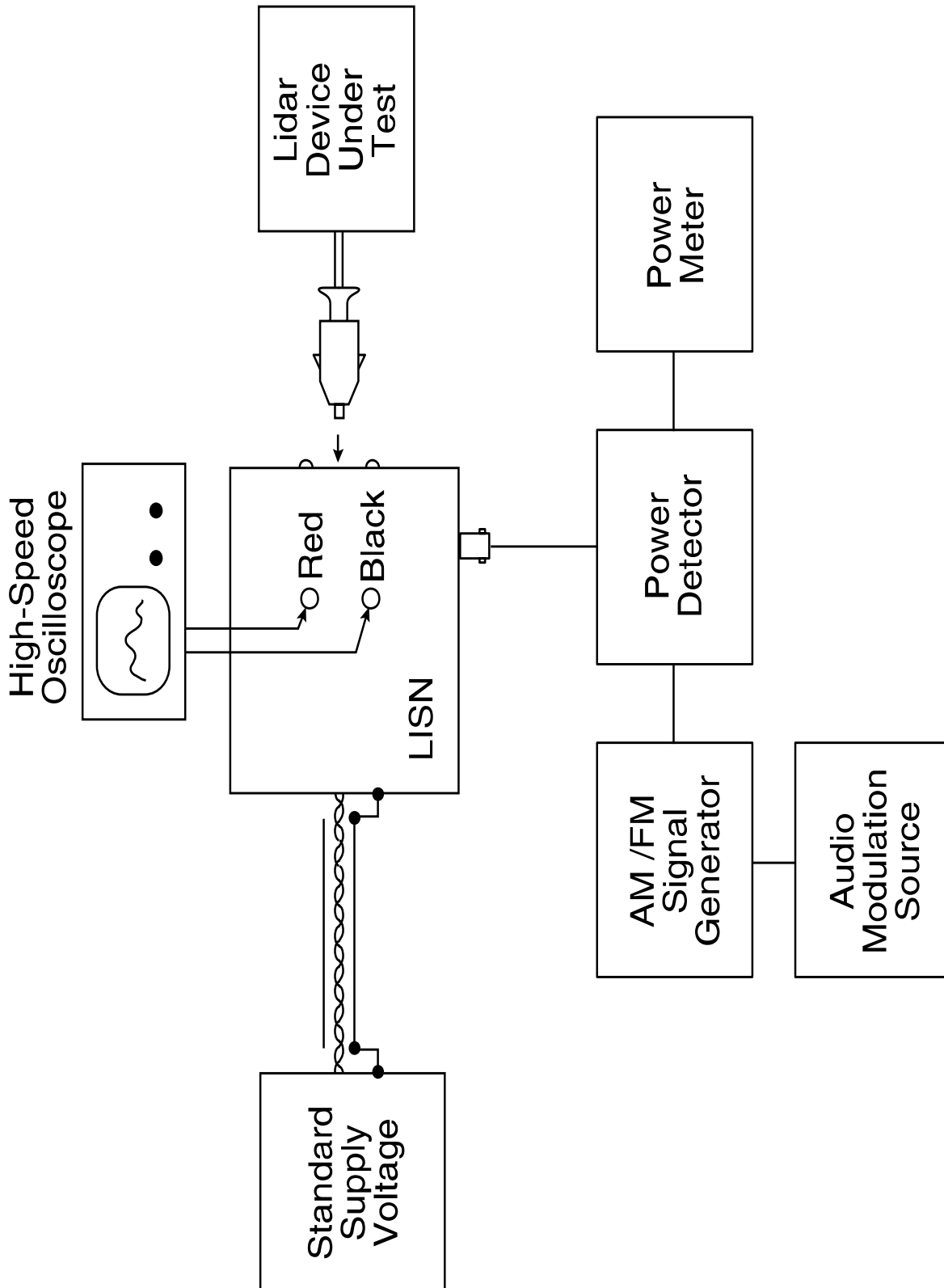

Figure 9. Block diagram of the radio-frequency test circuit